

P

P U B L I C U M

At its sole discretion, Figueras Seating reserves the right to modify, alter, or update the products, dimensions, and finishings described in this catalogue at any time without prior notice. We strive to ensure that all information presented is accurate and up to date, but errors, inaccuracies, or omissions related to product specifications may occur.

Figueras Seating assumes no responsibility for such discrepancies or any reliance on the information contained in this catalogue. We recommend consulting with a Figueras Seating representative for the most current product information and specifications. The representations of colours, textures, and finishes in this catalogue are approximate and may vary from the actual product due to the limitations of printing processes or differences in display settings on electronic devices.

Figueras Seating is a registered trademark. All products and brands displayed in this catalogue are registered and patented internationally.

Figueras Seating se reserva el derecho de modificar, alterar o actualizar los productos, dimensiones y acabados descritos en este catálogo en cualquier momento sin previo aviso. Nos esforzamos por asegurar que toda la información presentada sea precisa y esté actualizada, pero pueden ocurrir errores, inexactitudes u omisiones relacionadas con las especificaciones del producto.

Figueras Seating no asume ninguna responsabilidad por tales discrepancias o cualquier confianza en la información contenida en este catálogo. Recomendamos consultar con un representante de Figueras Seating para obtener la información más actual sobre los productos y sus especificaciones. Las representaciones de colores, texturas y acabados en este catálogo son aproximadas y pueden variar del producto real debido a las limitaciones de los procesos de impresión o diferencias en los ajustes de visualización de los dispositivos electrónicos.

Figueras Seating es una marca registrada. Todos los productos y marcas que aparecen en este catálogo están registrados y patentados internacionalmente.

PUBLICUM

SEATING COLLECTION

●●  FIGUERAS

LADIES & GENTLEMEN.

THE ART OF SEATING

Since 1929, designing, manufacturing, and installing seats worldwide

Our purpose goes beyond designing and manufacturing seats. Over the years, we have focused on creating spaces where people gather, interact, and share experiences. Each project we have participated in during nearly a century of history has been an opportunity to foster dialogue.

During this time, we have developed more than 40,000 projects globally. This translates to over 10 million seats installed. We are proud to have reached this milestone.

Because we firmly believe in innovation, we work to offer optimal solutions that meet and exceed our clients' needs and expectations. Our commitment to architecture and society is reflected in every project we undertake.

All of this makes Figueras synonymous with quality and excellence.

Desde 1929, diseñando, fabricando e instalando butacas en todo el mundo

Nuestro propósito trasciende al diseño y la fabricación de butacas. A lo largo de los años, nos hemos focalizado en generar espacios donde la gente se reúne, interactúa y comparte experiencias. Cada proyecto en el que hemos participado en este casi siglo de historia ha sido una oportunidad para fomentar el diálogo.

Durante este tiempo, hemos podido desarrollar más de 40.000 proyectos en todo el mundo. Esto se traduce en más de 10 millones de butacas instaladas. Nos enorgullece haber alcanzado este hito.

Precisamente porque creemos firmemente en la innovación, trabajamos para ofrecer soluciones óptimas que satisfagan y den respuesta a las necesidades y expectativas de nuestros clientes. Nuestro compromiso con la arquitectura y la sociedad se refleja en cada proyecto que emprendemos.

Todo esto, convierte a Figueras en sinónimo de calidad y excelencia.



Committed to Talent and Industry

Figueras is part of the Brand Corner Group, a family-owned group of industrial companies committed to sustainable growth and future development. With a broad international presence and a global vision, Brand Corner comprises 18 companies and over 1,800 people worldwide.

The group positions itself as a catalyst for industrial transformation and operates in sectors such as lighting, furniture, construction, small appliances, security closures, medical supplies, gas and oil, plastic injection, and cardboard and packaging.

Comprometidos con el talento y la industria

Figueras forma parte del Grupo Brand Corner, un grupo familiar de empresas industriales que apuesta por un futuro y crecimiento sostenible. Con una amplia presencia internacional y una visión global, Brand Corner está formada por 18 empresas y más de 1.800 personas en todo el mundo.

El grupo se posiciona como un catalizador de la transformación de la industria y opera en sectores como la iluminación, el mobiliario, la construcción, los pequeños electrodomésticos, los cierres de seguridad, el material sanitario, el gas y petróleo, la inyección de plástico y el cartón y embalajes.

DESIGNED & CRAFTED TO LAST

Talking about sustainability goes beyond mere product recyclability. For nearly a century, Figueras has been committed to creating durable and high-quality solutions to minimize the environmental and social impact of our activities, based on circular economy principles.

All our new products are designed under ISO 14006 certification. This demonstrates Figueras' concern and commitment to incorporating an eco-design management system that ensures the identification, control, and continuous improvement of the environmental aspects of our products, as well as the incorporation of processes that enhance and reduce environmental impact.

Designing with durability in mind means creating products that are resilient, functional, and capable of extending their useful life. This involves selecting high-quality materials and reliable partners. Additionally, we have introduced a series of standardized initiatives applied across our products, such as the use of water-based varnishes free of VOCs, powder coating on metal components (without VOC emissions), and the use of polyester fabrics with recycled content that guarantee the same quality and durability as non-recycled yarns.

At Figueras, we design and manufacture responsibly.

Hablar de sostenibilidad trasciende la mera reciclabilidad de los productos. Durante casi un siglo, en Figueras nos hemos comprometido a crear soluciones duraderas y de calidad para minimizar el impacto ambiental y social de nuestra actividad, basándonos en los principios de la economía circular.

Todos nuestros nuevos productos están diseñados bajo la certificación ISO 14006. Esto demuestra la preocupación y el compromiso de Figueras por incorporar un sistema de gestión del ecodiseño que garantice la identificación, control y una mejora continua de los aspectos ambientales de nuestros productos, así como la incorporación de procesos que mejoren y reduzcan el impacto ambiental.

Diseñar con la durabilidad en mente, implica la creación de productos que sean resistentes, funcionales y capaces de prolongar su vida útil. Esto implica la selección de materiales de alta calidad y colaboradores de confianza. Además, hemos introducido una serie de iniciativas homologadas que se aplican de forma transversal a nuestros productos como la aplicación de barnices de base acuosa libres de COV, la aplicación de pintura en polvo sobre componentes metálicos (sin emisión de COV), y la utilización de tejidos de poliéster con contenido de origen reciclado que garantizan la misma calidad y durabilidad que los de filatura no reciclada.

En Figueras diseñamos y fabricamos con responsabilidad.





P

PUBLICUM

SEATING COLLECTION

Publicum is a declaration of our philosophy and mission. It represents our dedication to providing seating that not only meets the needs of our clients but also enriches the collective experience of those who gather in auditoriums, conference rooms, or convention centers. It is a name that encapsulates our history, our purpose, and our vision for the future of public spaces.

The design of a seat for an auditorium is fundamental. Various parameters such as comfort and ergonomics, acoustics, and visibility have a direct impact on the audience's experience. At Figueras, we understand this very well. Since installing our first auditorium in the 1970s, we have worked tirelessly to continue innovating through our own designs or collaborating with architects and designers to create spaces that foster dialogue and the expression of ideas.

Our mission is to continuously improve the experience by offering seating that meets the specific needs of each space, ensuring the highest standards of quality. At Figueras, we are experts in providing customized solutions that fulfill functionality and elevate the space and prestige of each installation.

Publicum es una declaración de nuestra filosofía y misión. Representa nuestra dedicación a proporcionar asientos que no solo cumplen con las necesidades de nuestros clientes, también enriquecen la experiencia colectiva de quienes se reúnen en auditorios, salas de conferencias o centros de congresos. Es un nombre que encapsula nuestra historia, nuestro propósito y nuestra visión para el futuro de los espacios públicos.

El diseño de una butaca para un auditorio es fundamental. Diversos parámetros, como la comodidad y la ergonomía, la acústica y la visibilidad, tienen un impacto directo en la experiencia del público. En Figueras lo sabemos muy bien. Desde la instalación de nuestro primer auditorio en la década de 1970, hemos trabajado incansablemente para seguir innovando mediante diseños propios o colaborando con arquitectos y diseñadores para crear espacios donde se fomente el diálogo y la expresión de ideas.

Nuestra misión es seguir mejorando la experiencia, ofreciendo asientos que den respuesta a las necesidades de cada espacio, garantizando los más altos estándares de calidad. En Figueras, somos expertos en proporcionar soluciones a medida que cumplen con la funcionalidad y elevan el espacio y el prestigio de cada instalación.

MADE TO MEASURE



Design is a fundamental and distinctive pillar of Figueras. Our pursuit of excellence goes beyond aesthetics to maximize the functionality of our products and meet the needs and demands of our clients. Our design department has extensive experience in creating bespoke products, ensuring that every detail is meticulously considered.

Our collaborations with architecture and design firms, merging our knowledge with their expertise to conquer even the most complex challenges, allow us to transform visionary ideas into tangible realities, ensuring that functionality, aesthetics, and innovation are at the forefront of every project.

We are proud to say that unique seats conceived by Figueras are part of exceptional spaces. Renowned projects such as the Philharmonie de Paris (France), Princeton University's McCosh50 Auditorium (USA), The Glasshouse International Centre for Music in Gateshead (UK), or Madrid's Teatros del Canal (Spain) are prime examples of the 'Made to Measure' concept developed by Figueras.

Figueras' commitment to offering personalized solutions tailored to each project ensures that our products integrate perfectly with all types of environments, providing design, comfort, and practicality in every space.

El diseño es un pilar fundamental y distintivo de Figueras. Nuestra búsqueda de la excelencia va más allá de la estética para maximizar la funcionalidad de nuestros productos y satisfacer las necesidades y demandas de nuestros clientes.

Nuestro departamento de diseño cuenta con una amplia experiencia para crear un producto hecho a medida, asegurando que cada detalle sea considerado meticulosamente. Nuestras colaboraciones con firmas de arquitectura y diseño, fusionando nuestros conocimientos con su experiencia para conquistar, incluso, los desafíos más complejos, nos permiten transformar ideas visionarias en realidades tangibles, asegurando que la funcionalidad, la estética y la innovación estén a la vanguardia de cada proyecto.

Estamos orgullosos de poder decir que butacas singulares concebidas por Figueras forman parte de espacios únicos. Proyectos tan reconocidos como la Philharmonie de Paris (Francia), el Auditorio McCosh50 de la Universidad de Princeton (EE.UU.), el Glasshouse International Centre for Music en Gateshead (Reino Unido) o los Teatros del Canal en Madrid (España) son ejemplos destacados del concepto 'Made to Measure' (hecho a medida) desarrollado por Figueras.

El compromiso de Figueras ofreciendo soluciones personalizadas y adaptadas a cada proyecto asegura que nuestros productos se integren perfectamente con todo tipo de entornos, proporcionando diseño, confort y practicidad en cada espacio.

2

FLEX

COLLECTION

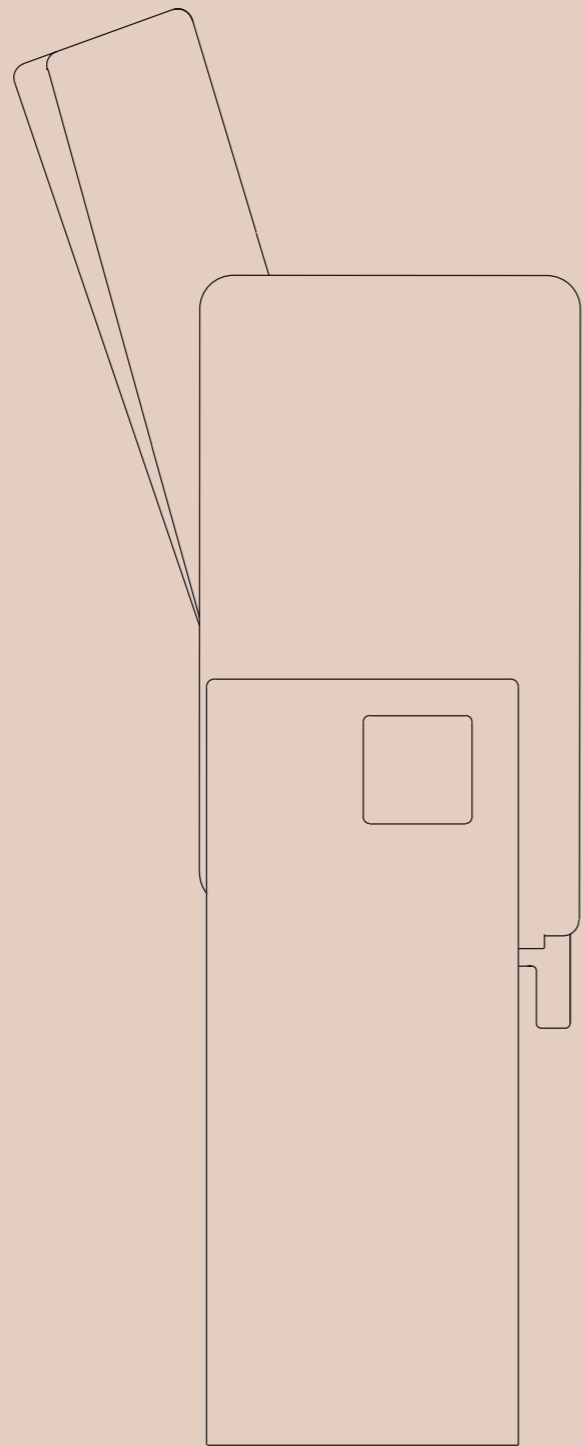

F L E X

6 0 3 5

FLEX

6035

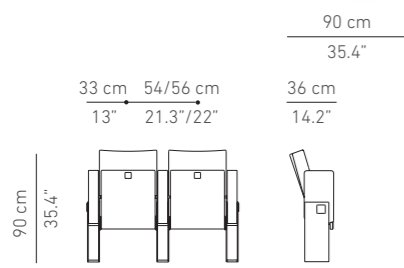

Flex 6035

FLEX

6035



Disseny Hub (Barcelona, Spain)
Arch. MBM Arquitectes



Museu Agbar de les Aigües (Cornellà de Llobregat, Spain)
Arch. UNEN



Press Room - Catalan Parliament (Barcelona, Spain)



Music School and Concert Hall (Ventspils, Latvia) © Raimonds Birkenfelds
Arch. David Cook, Martin Haas & Stephan Zemmrich Studio



ACCESSORIES AND FINISHES / ACCESORIOS Y ACABADOS



Seat numbering
Numeración de asiento



Wood finishings
Acabados en madera



Row numbering
Numeración de fila

PUBLICUM

SEATING COLLECTION

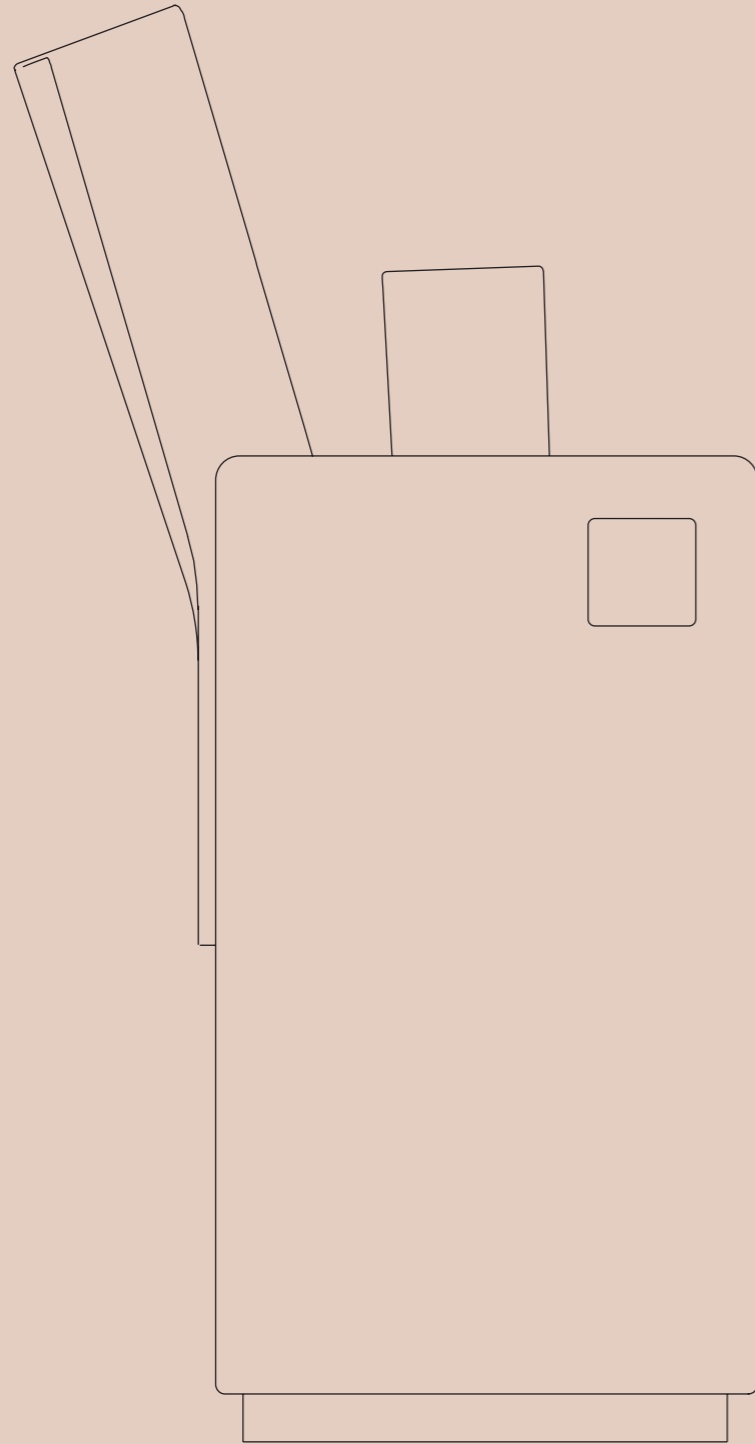

F L E X

6 0 3 6

FLEX

6036

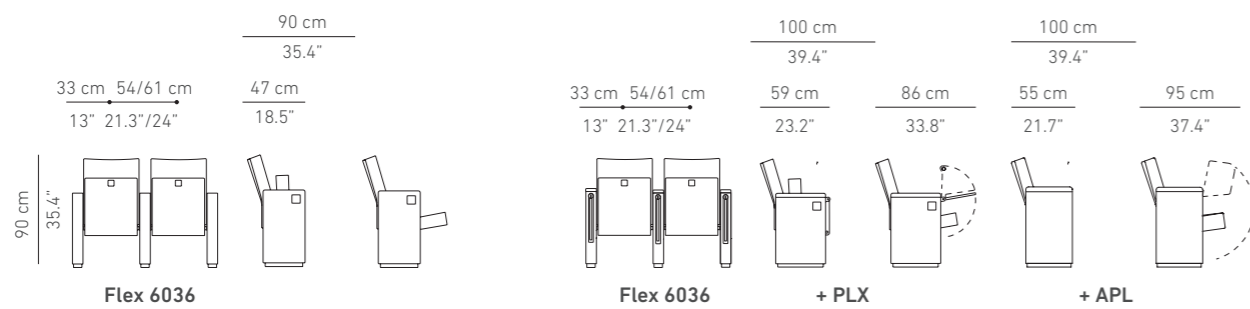

FLEX

6036



Len Lye Centre (New Plymouth, New Zealand)
Arch. Patterson Architects



Museum of the Second World War (Gdansk, Poland)
Arch. Studio Architektoniczne Kwadrat



Cuatrecasas Office (Madrid, Spain)
Arch. GCA Arquitectes

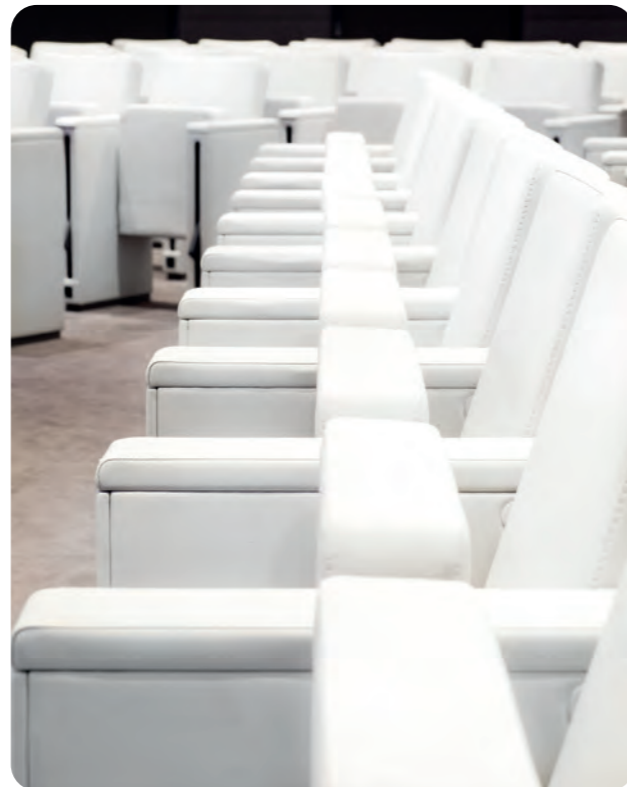

Banc Sabadell HQ (Madrid, Spain)
Arch. Tasvalor Arquitectura



ACCESSORIES AND FINISHES_ACCESORIOS Y ACABADOS



Integrated tablet in the side panel
Mesa integrada en el costado

MESAS_TABLES



APL tablet
Mesa APL



PLX tablet
Mesa PLX

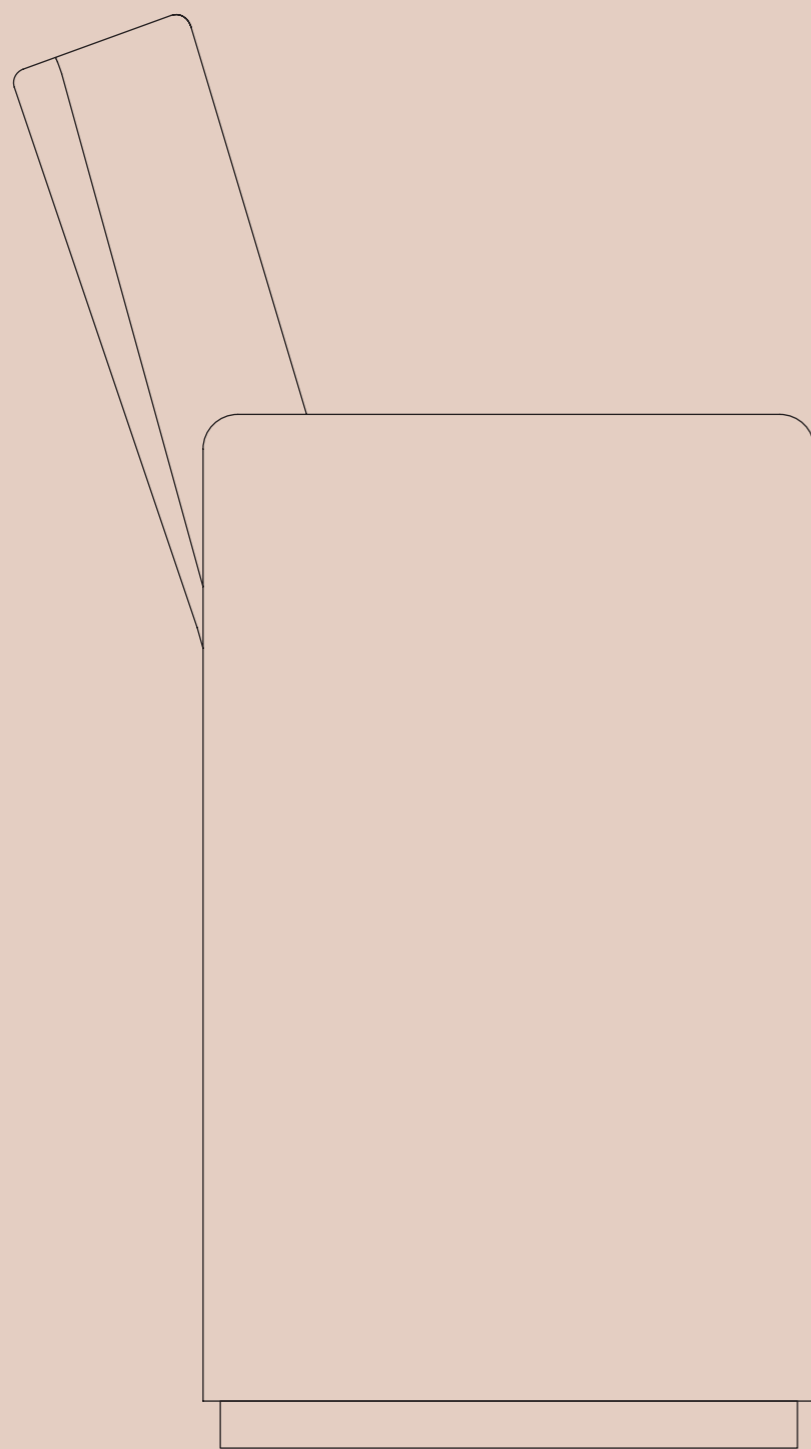

F L E X

6 0 7 6

FLEX

6076

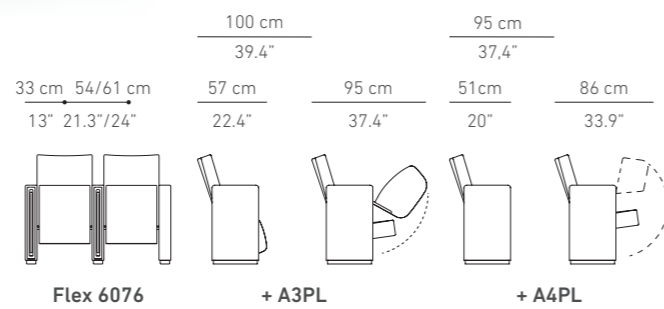
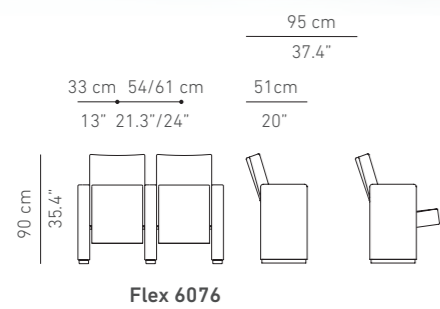

FLEX

6076



CaixaForum (Valencia, Spain)
Arch. Enric Ruiz Gelí. ©Miguel-Lorenzo-CaixaForum



Cuatrecasas HQ (Barcelona, Spain)
Arch. GCA Arquitectes



Ag2r La Mondiale (Paris, France)
Arch. Lacau Associés



Musée d'Orsay (Paris, France)
Arch. Antoine Rouzeau



Auditori Valentí Fuster (Cardona, Spain)
Arch. BCQ Arquitectura Barcelona



ACCESSORIES AND FINISHES / ACCESORIOS Y ACABADOS



Seat numbering
Numeración de asiento



Wood finishings
Acabados en madera



APL tablet
Mesa APL



PLX tablet
Mesa PLX

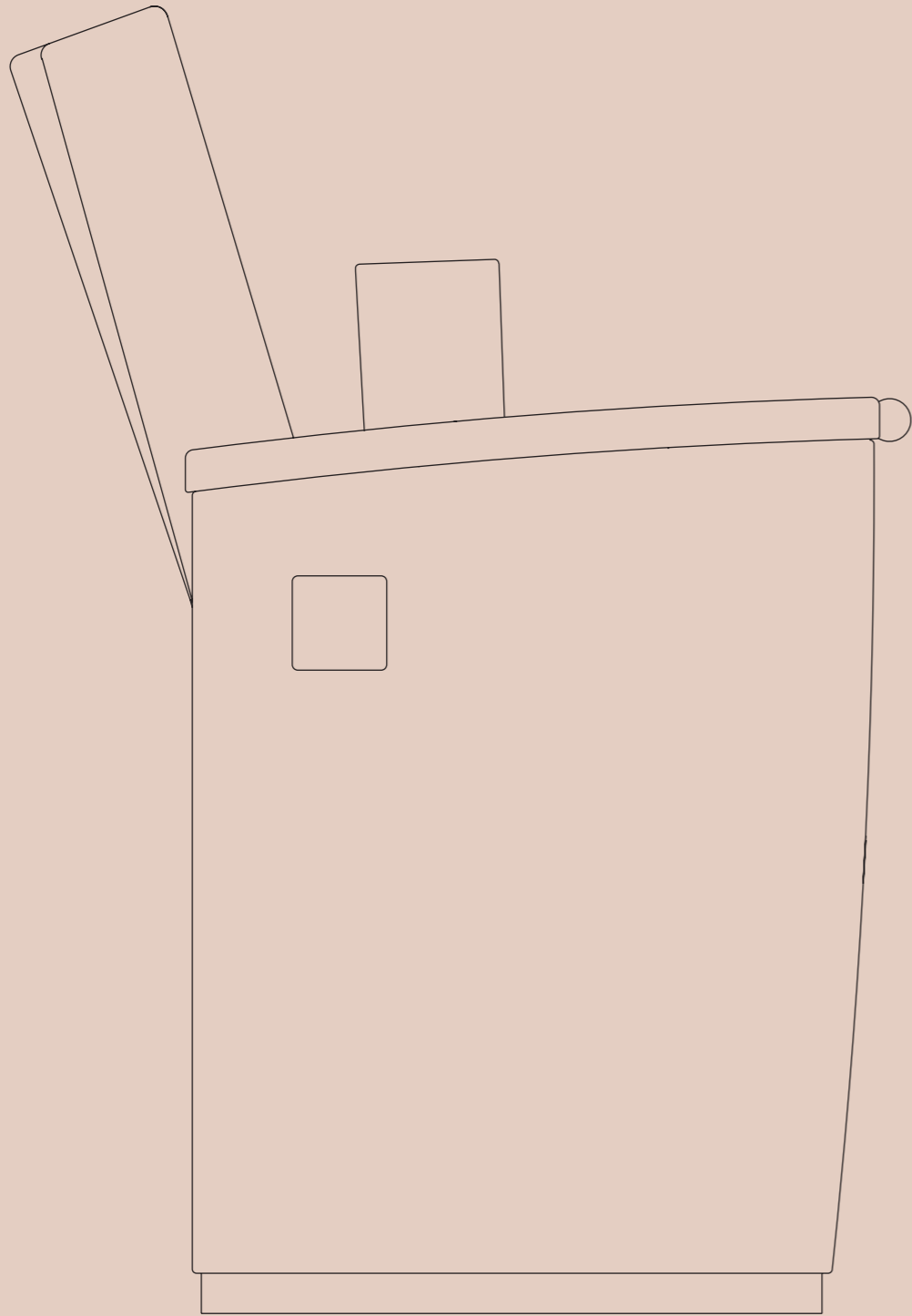

F L E X

6 0 4 0 G P L

FLEX

6040 GPL

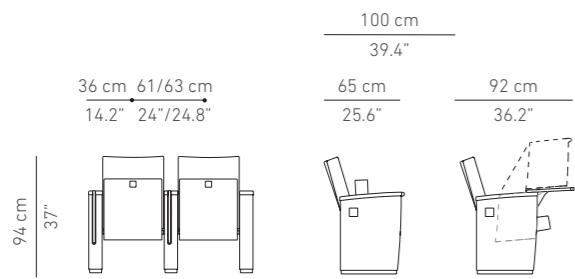

Flex 6040 GPL



FLEX

6040 GPL



Torre Diagonal One (Diagonal Zero Zero), (Barcelona, Spain)
Arch. Enric Massip, EMBA Arquitectura



ACCESSORIES AND FINISHES / ACCESORIOS Y ACABADOS



Row numbering
Numeración de fila



Seat numbering
Numeración de asiento



GPL tablet in wood finishing
Mesa GPL en madera



MICROFLEX

6 0 6 1

MICROFLEX

6061

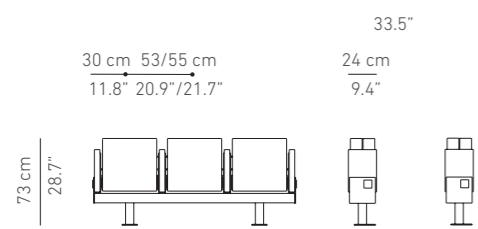

Flex 6061



MICROFLEX

6061



Palacio de Congresos de Córdoba (Córdoba, Spain)
Arch. LAP Arquitectos



Centro Pompidou (Málaga, Spain)
Arch. Javier Pérez De La Fuente, Juan Antonio Marín Malavé



Celler de Peralada (Peralada, Spain)
Arch. RCR Arquitectes



CEIBS (Shanghai, China)



Casa de Cultura de Lugones (Siero, Spain)
Arch. Benito Diaz, María José Fernández



ACCESSORIES AND FINISHES_ACCESORIOS Y ACABADOS



Beam-mounted folding seat
Butaca plegable montada en barra



Seat numbering
Numeración de asiento



Row numbering
Numeración de fila



Side panel in wood finishing
Acabado lateral en madera



FLAME

1 3 1 0 7

FLAME

13107

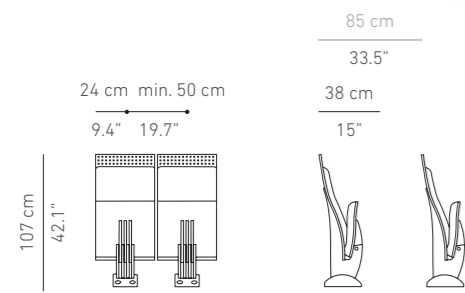

Flame 13107

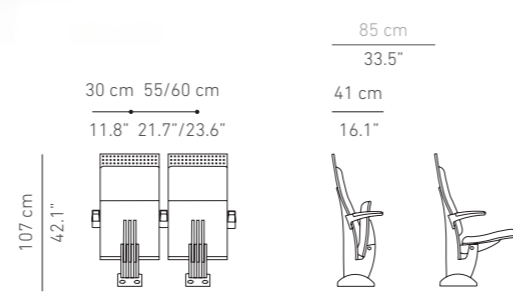

Flame 13107 + Armrest



FLAME

13107

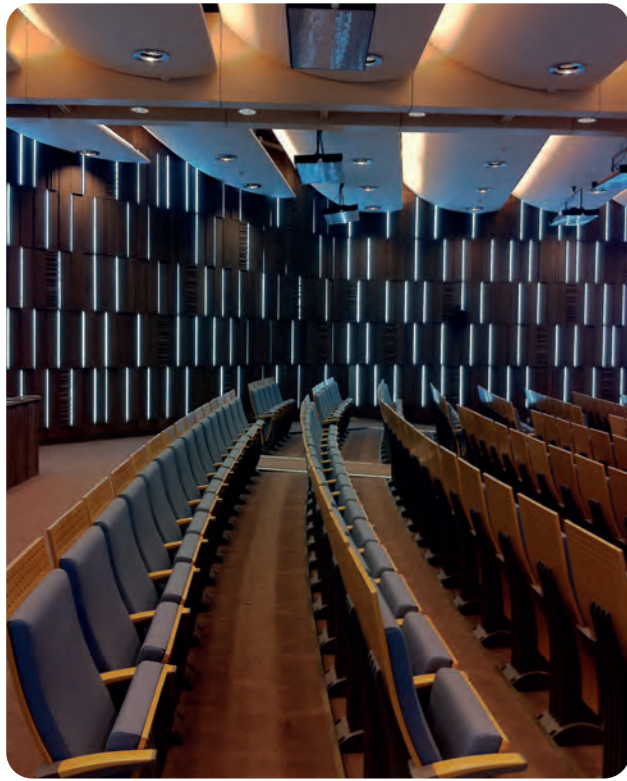

RIA Novosti (Moscow, Russia)
Arch. Georgui Trafimov



Templo de Salomão (São Paulo, Brazil)
Arch. Rogério Silva de Araújo



The White House Press Room (Washington DC, USA)
Arch. Bill London, RTKL Associates Inc.



Gorgona Hall at Museum of Contemporary Art, (Zagreb, Croatia)
Arch. Igor Franic



ACCESSORIES AND FINISHES / ACCESORIOS Y ACABADOS



Armrest in wood finishing
Brazo con acabado en madera



Pedestal with seat numbering
Pie con numeración de asiento



Armrest and side panel in wood finishing
Brazo y costado con acabado de madera



PLX tablet integrated
Mesa PLX integrada



S E N S Ó
1 3 1 1 3

SENSÓ

13113

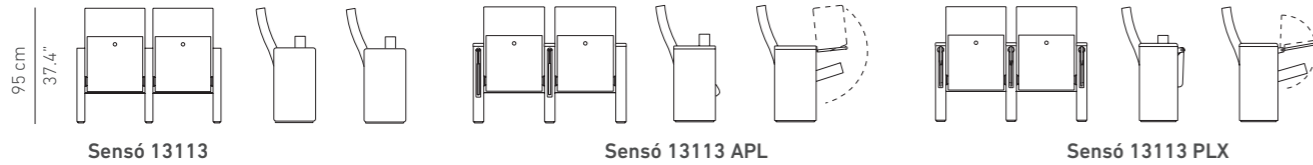

SENSÓ

13113



Centre de congrès de l'Aube (Troyes, France) ©Roland Halbe
Arch. José Ignacio Legazasoro



Palacio de Congresos y Exposiciones (Huesca, Spain)
Arch. Pedro Lafuente, Rafael Beneytez



Consejo General del Poder Judicial (Madrid, Spain)



Arent Fox (Washington DC, USA)
Arch. Christian Amolsch, Studios Architecture



ACCESSORIES AND FINISHES_ACCESORIOS Y ACABADOS



Seat numbering
Numeración de asiento



Row numbering
Numeración de fila



Backrest, seat and side panels with wood finishing
Cubierta trasera, asiento y costados con acabado en madera



Back and side panels with wood finishing
Cubierta trasera y costado con acabado en madera



APL table integrated
Mesa APL integrada



PLX Table integrated
Mesa PLX integrada



L Y O N

1 3 1 0 8

LYON

13108

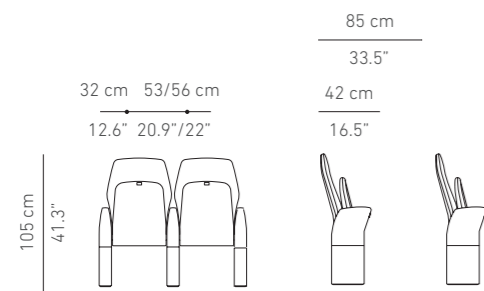

Lyon 13108

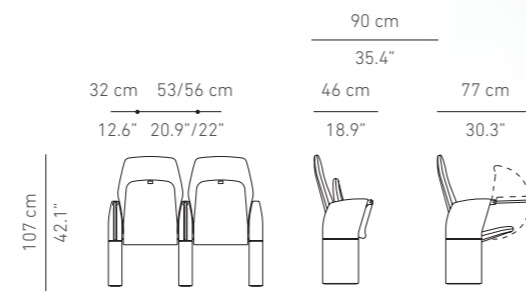

Lyon 13108 PLX



LYON

13108

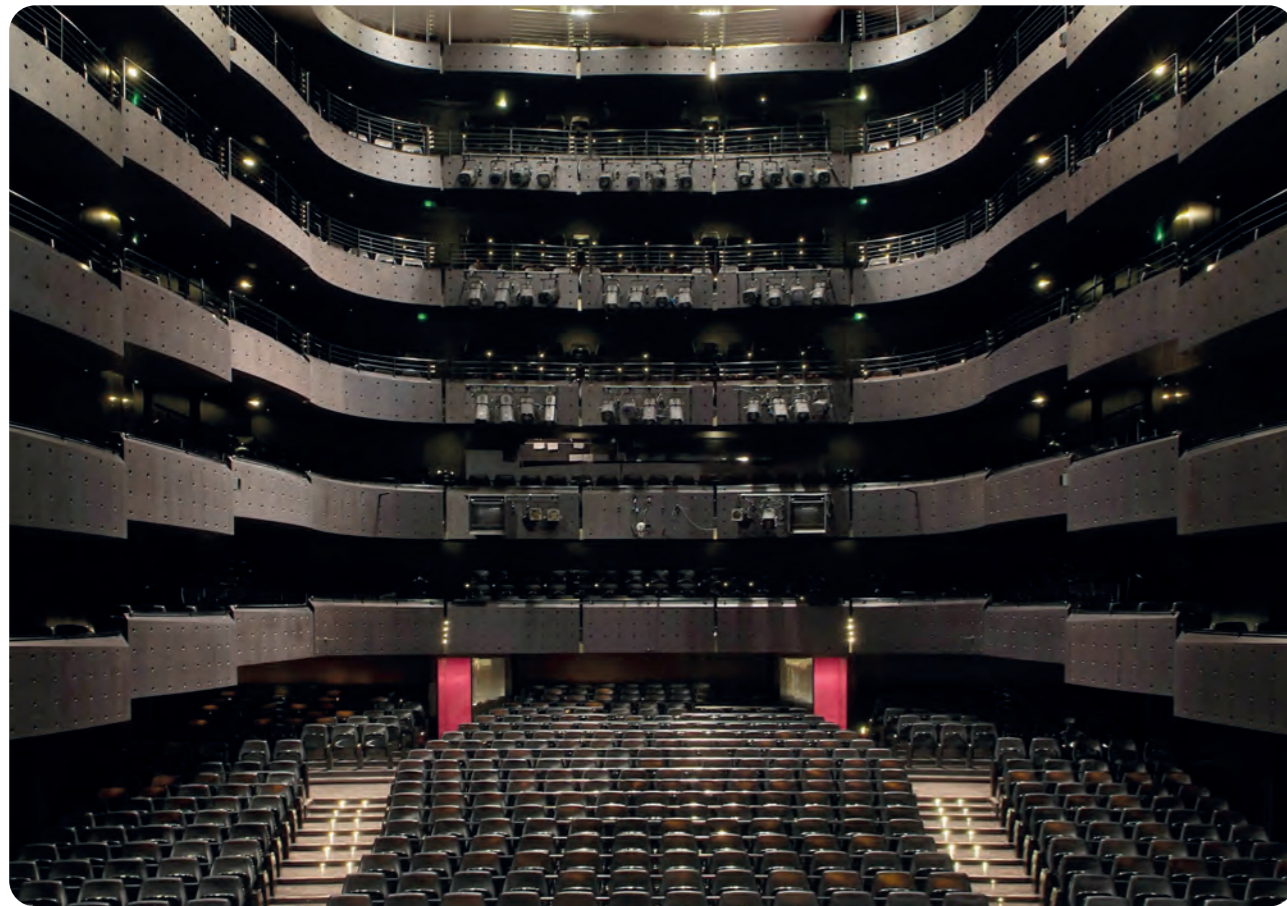

Opera de Lyon (Lyon, France)
Arch. Ateliers Jean Nouvel



Museo Nacional Centro de Arte Reina Sofía (Madrid, Spain)
Arch. Ateliers Jean Nouvel. ©Jose Luis Municio



Dresdner Bank (Frankfurt, Germany)
ABB Architekten



CEI (Italian Episcopal Conference)
(Rome, Italy)



Palacio de Congresos de Málaga (Málaga, Spain)
Arch. Angel Asenjo y Asociados



ACCESSORIES AND FINISHES / ACCESORIOS Y ACABADOS



Frontal view
Vista frontal



Perforated shell for acoustic performance
Cubeta perforada con propiedades acústicas



Seat numbering
Numeración de asiento



V I R T U S

1 3 2 0 5

VIRTUS

13205

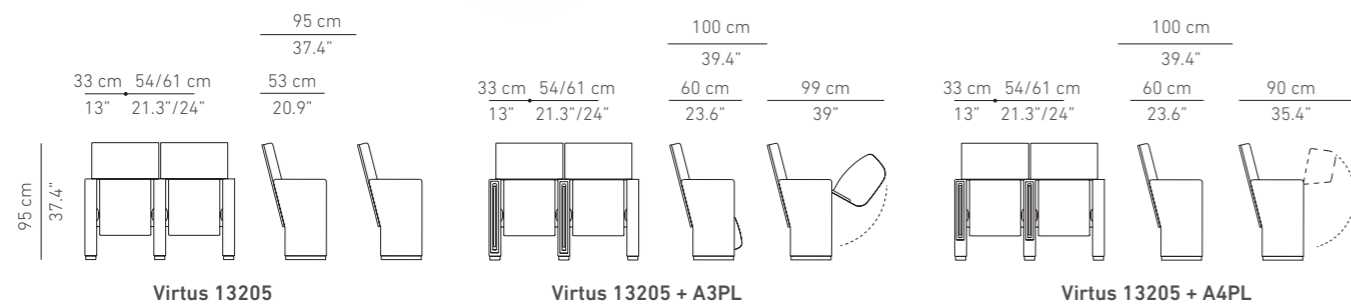

VIRTUS

13205



Chevron Australia (Perth, Australia)
Arch. Gensler



Hospital HLA El Ángel
(Málaga, Spain)



Çamlica Mosque (Istanbul, Turkey)



ACCESSORIES AND FINISHES_ACCESORIOS Y ACABADOS



Side panels finishings in wood
Costados acabados en madera



Upholstered backrest
Respaldo tapizado



Front view of the seat
Detalle frontal de la butaca



A3PL table integrated
Mesa A3PL integrada



A4PL table integrated
A4PL mesa integrada



S C A L A
1 4 8

SCALA

148

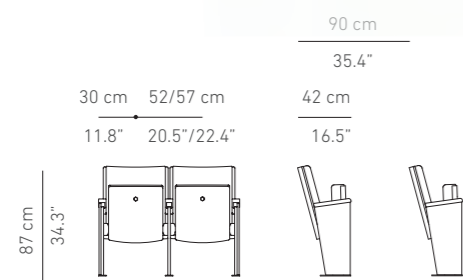

Scala 148

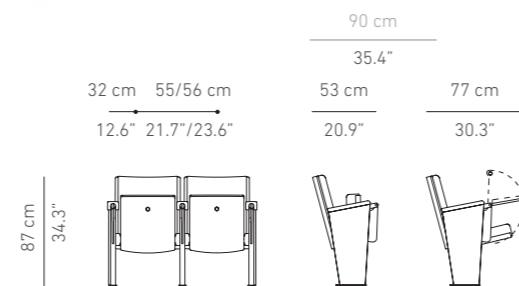

Scala 148 PLX

SCALA

148

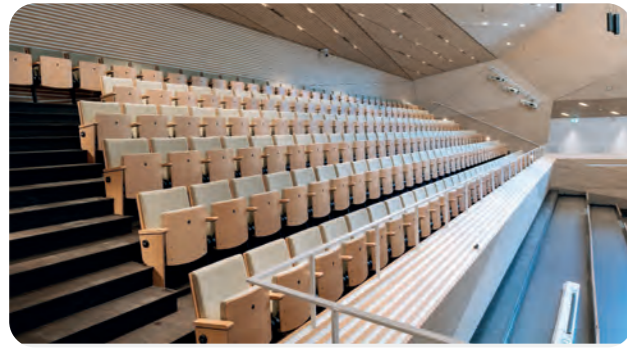

Andermatt Concert Hall (Andermatt, Switzerland)
Arch. Studio Seilern Architects



La Cidrerie (Beuzeville, France)
Arch. Sunmetron



Auditorio Duval Pestana
(Lagos, Portugal)



Ministry of Foreign Affairs (Riyadh, KSA)
Arch. Henning Larsen Architects



ACCESSORIES AND FINISHES / ACCESORIOS Y ACABADOS



Shared armrest
Brazo compartido



Row numbering
Numeración de fila



Seat numbering
Numeración de asiento



PLX tablet
Mesa PLX



A P T U M

2 4 6 - 2 4 7

APTUM

246, 247

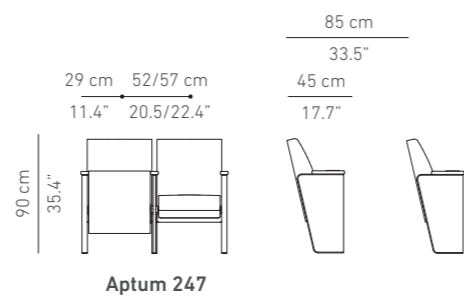
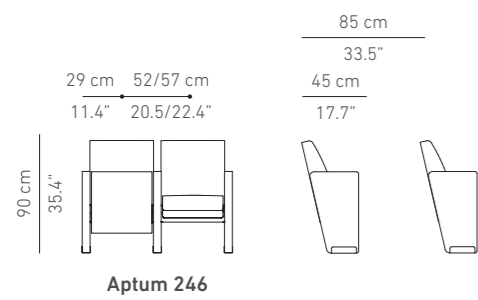
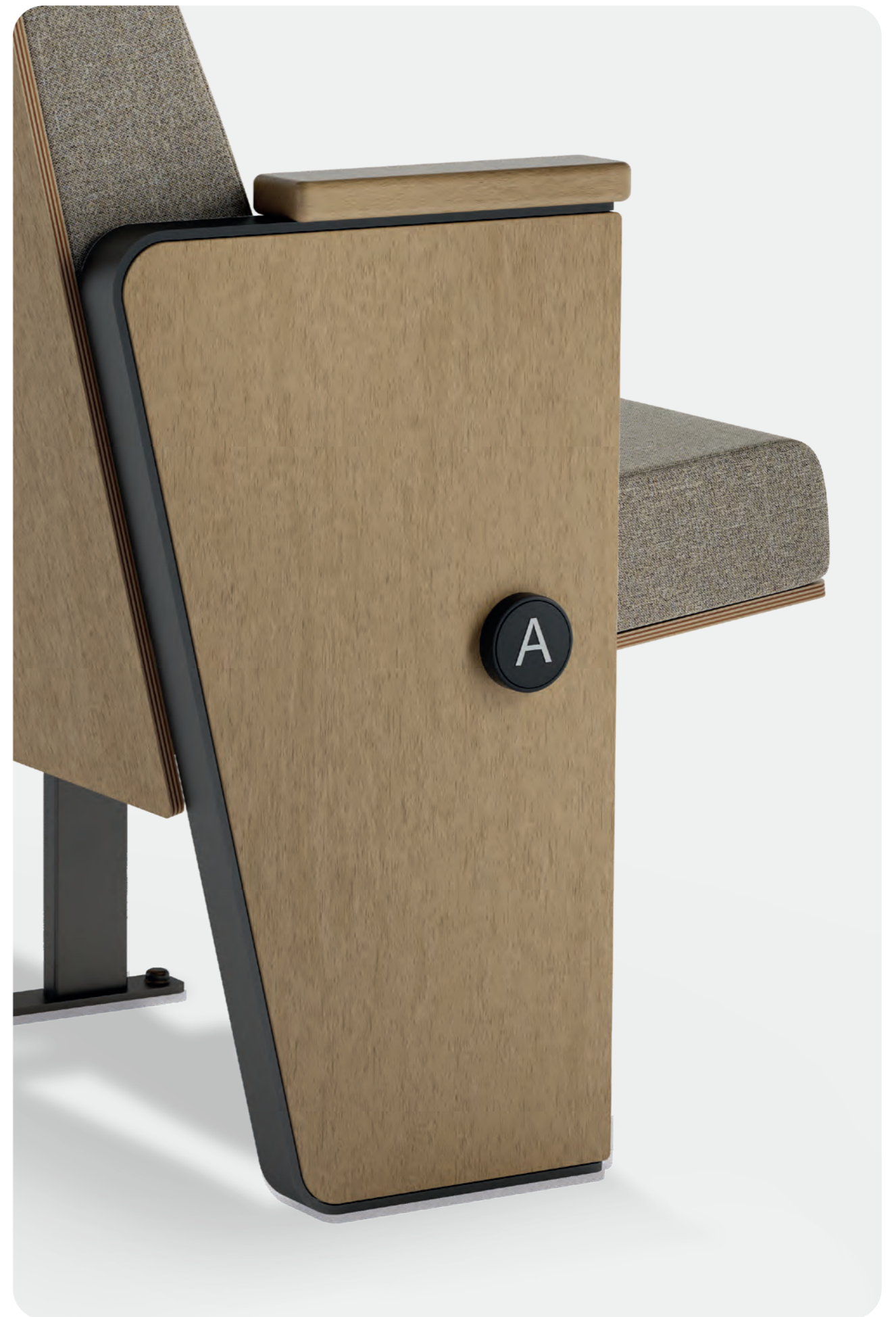

APTUM

246, 247



The Media Pro Studio
(Madrid, Spain)



El Vicenç de la Mar (Cala Sant Vicenç, Mallorca, Spain)
Arch. Rafael Balaguer, Magnus Ehrlund, Espacio Scena



ACCESSORIES AND FINISHES_ACCESORIOS Y ACABADOS



Aptum 246 with side panel in wood finishing
Aptum 246 con costadillo con acabado de madera



Aptum 247 with armrest in wood finishing
Aptum 247 con reposabrazos con brazo de madera



Seat numbering
Numeración de asiento



PLX tablet
Mesa PLX



MINISPACE

COLLECTION

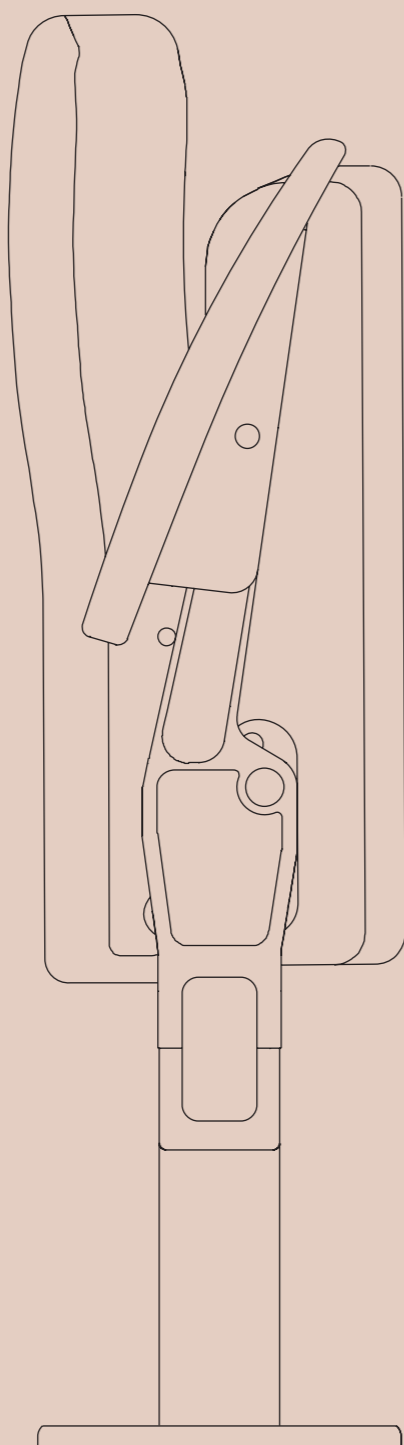

MINISPACE

5 0 6 4

MINISPACE

5064

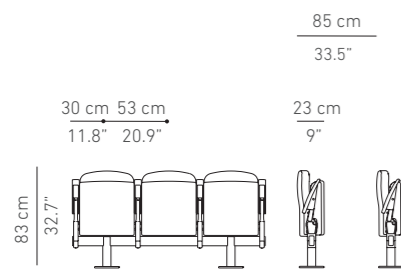

Minispace 5064

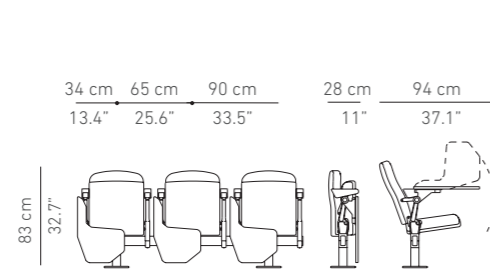

Minispace 5065

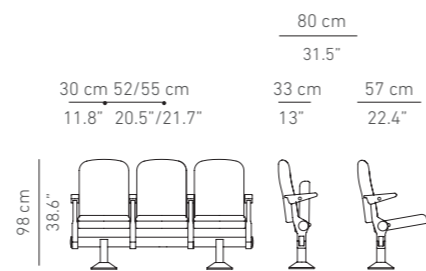

Minispace 5064 Fix

MINISPACE

5064



Musée Picasso
(Paris, France)



La Pedrera (Barcelona, Spain)
Arch. MBM Arquitectes



Mediatheque des Capucins (Brest, France)
Arch. Canal Architecture



Melbourne Conservatorium of Music
(Melbourne, Australia)



Francis Crick Institute (London, UK) ©Paul Grundy
Arch. PLP Architecture



ACCESSORIES AND FINISHES / ACCESORIOS Y ACABADOS



Minispace 5064 Fix
Fixed backrest. Respaldo fijo



Armrest in wood finishing
Reposabrazos en madera

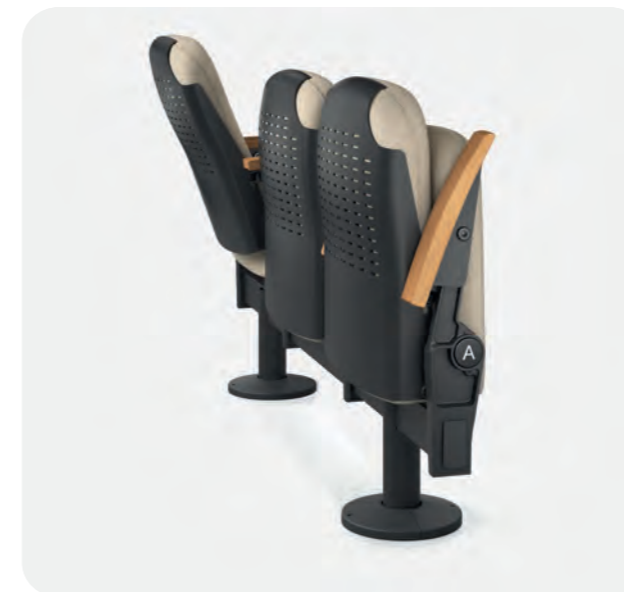

Backrest with metallic finishing
Respaldo con acabado metálico



PL writing tablet
Mesa de escritura PL

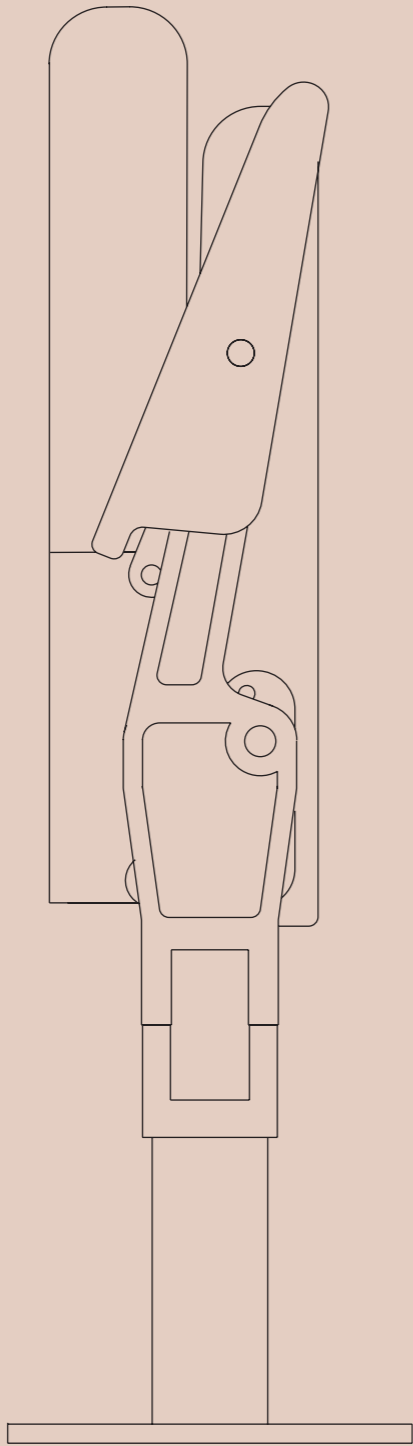

MINISPACE

5 0 6 7

MINISPACE

5067

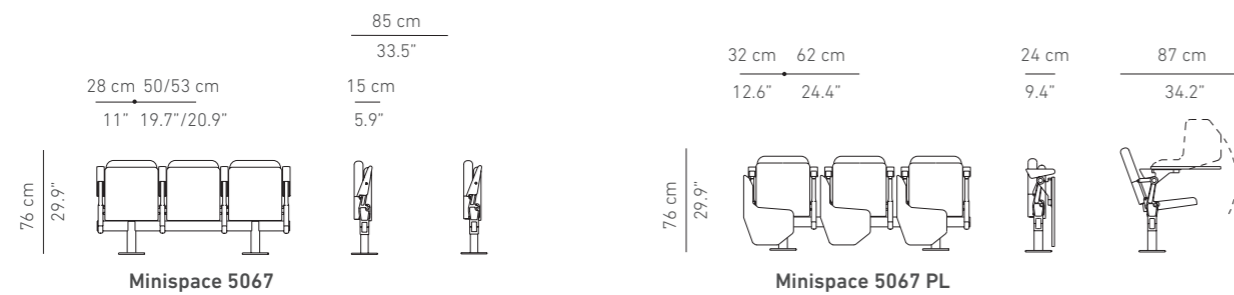

MINISPACE

5067



Centre Cultural Robert Brillas (Esplugues de Llobregat, Spain)
Arch. Batlle i Roig



Centro de Exposiciones, Ferias y Convenciones de Córdoba
(Córdoba, Spain)



Salle Paderewski, Casino de Montbenon
(Lausanne, Switzerland)



HOMS Health and Wellness Centre
(Santiago de los Caballeros, Dominican Republic)



Auditorio Alfredo Kraus (Las Palmas, Spain)
Arch. Oscar Tusquets



ACCESSORIES AND FINISHES / ACCESORIOS Y ACABADOS



Backrest with metallic finishing
Respaldo con acabado metálico



Minispace 5067 Fix
Fixed backrest. Respaldo fijo



Row and seat numbering
Numeración de fila y asiento



PL tablet
Mesa PL

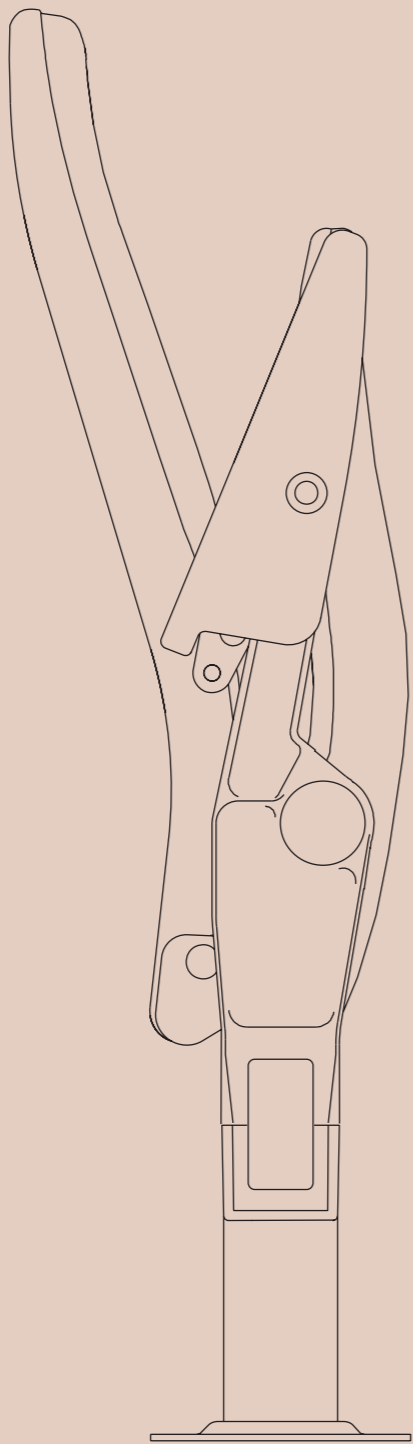

MINISPACE

5 0 6 9

MINISPACE

5069

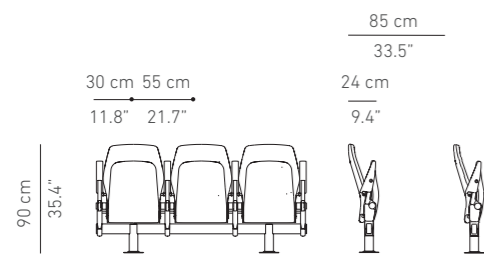

Minispace 5069



MINISPACE

5069



Centrum Kongresowe Targi Kielce (Kielce, Poland)
Arch. Barbara Sredniawa



ACCESSORIES AND FINISHES / ACCESORIOS Y ACABADOS



Frontal view
Vista frontal



Protective polypropylene shell for seat and backrest
Carcasa protectora de polipropileno para el asiento y el respaldo



Perforated shell for acoustic performance
Cubeta perforada con propiedades acústicas

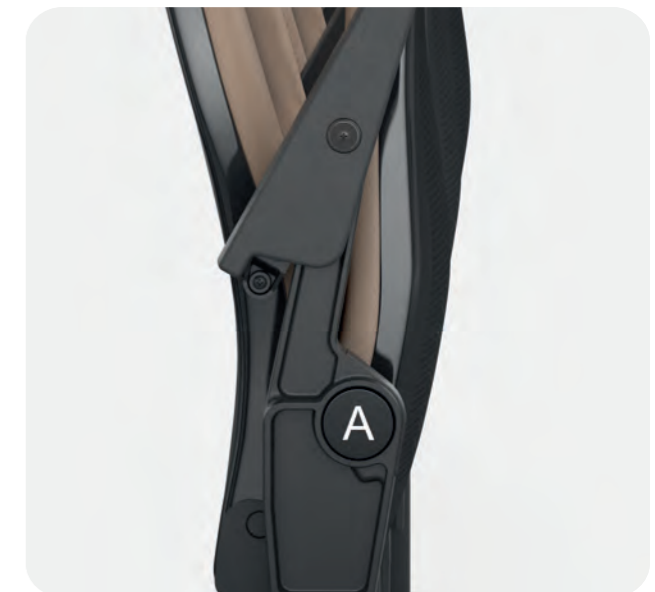

Row numbering
Numeración fila

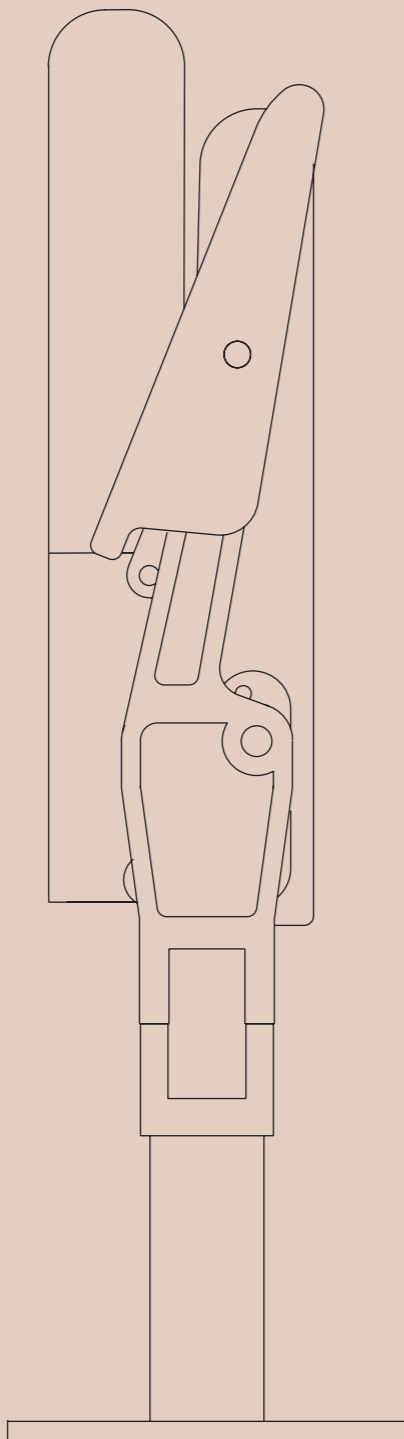

MINISPACE

5 0 7 1

MINISPACE

5071

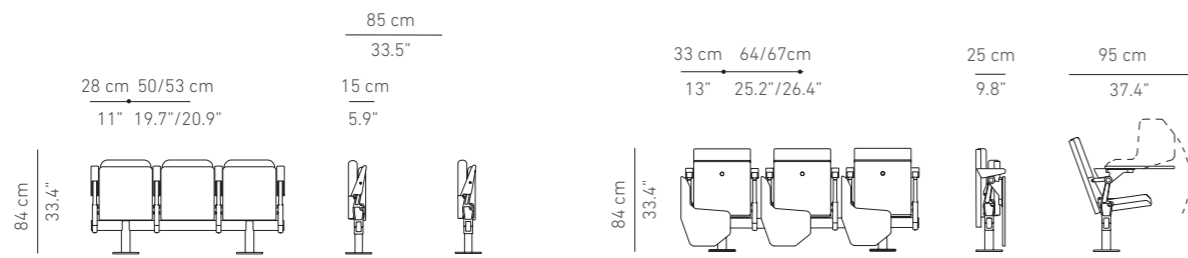
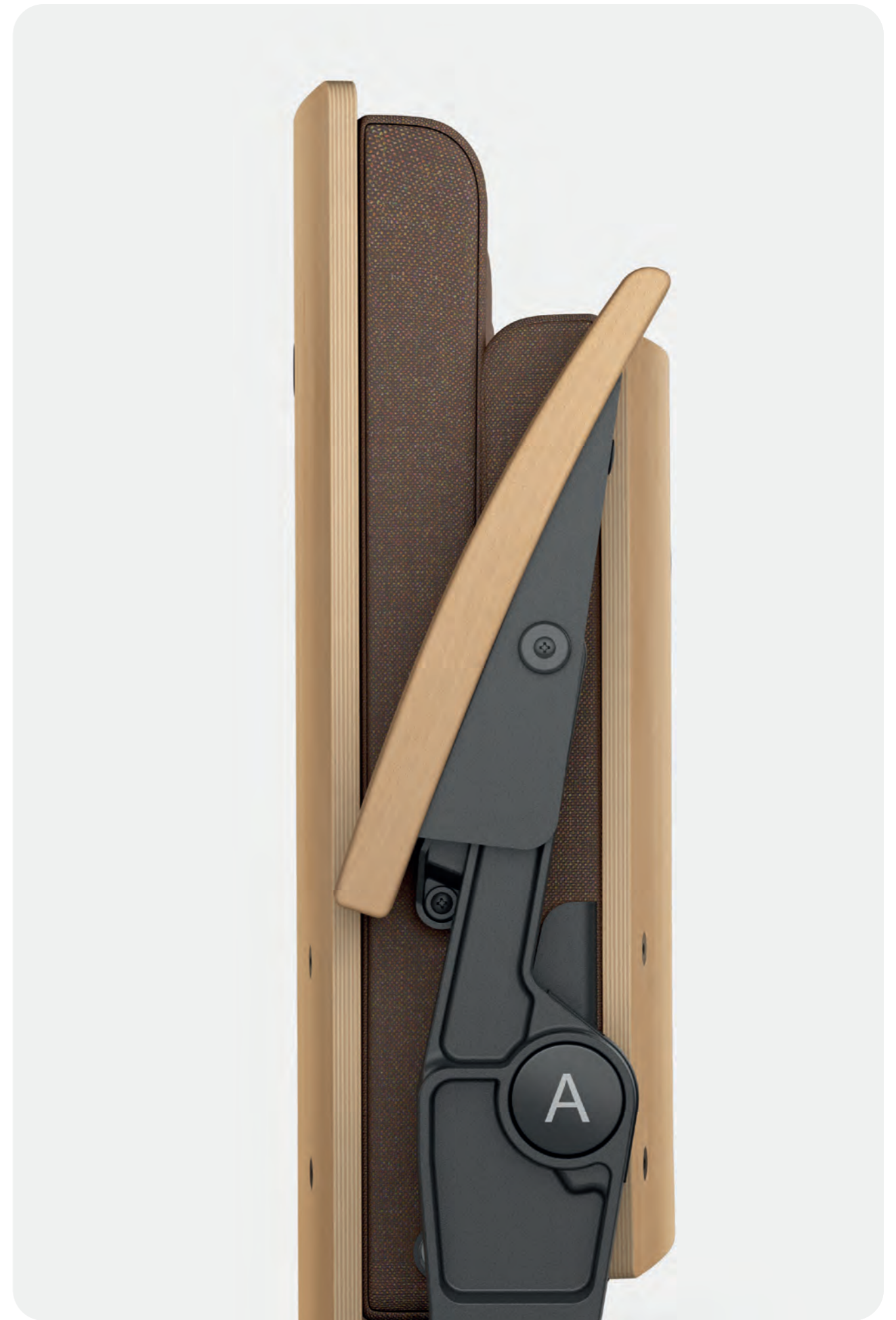

Minispace 5071

Minispace 5071 PL

MINISPACE

5071



Cité Internationale de la Langue Française (Villers-Côterets, France)
Photography © Simon Guesdon



Consulate General of France (Edinburgh, United Kingdom)



Reduta Philharmonic (Bratislava, Slovakia)



Hospital de Sant Joan de Déu (Barcelona, Spain)
Arch. Rafael Delgado



L'Atlantida - Centre d'Arts Escèniques d'Osona (Vic, Spain)
Arch. Josep Llinàs



ACCESSORIES AND FINISHES / ACCESORIOS Y ACABADOS



Open armrest and row numbering
Reposabrazos abierto y numeración de fila



Row and seat numbering
Numeración de fila y asiento



PL tablet
Mesa PL

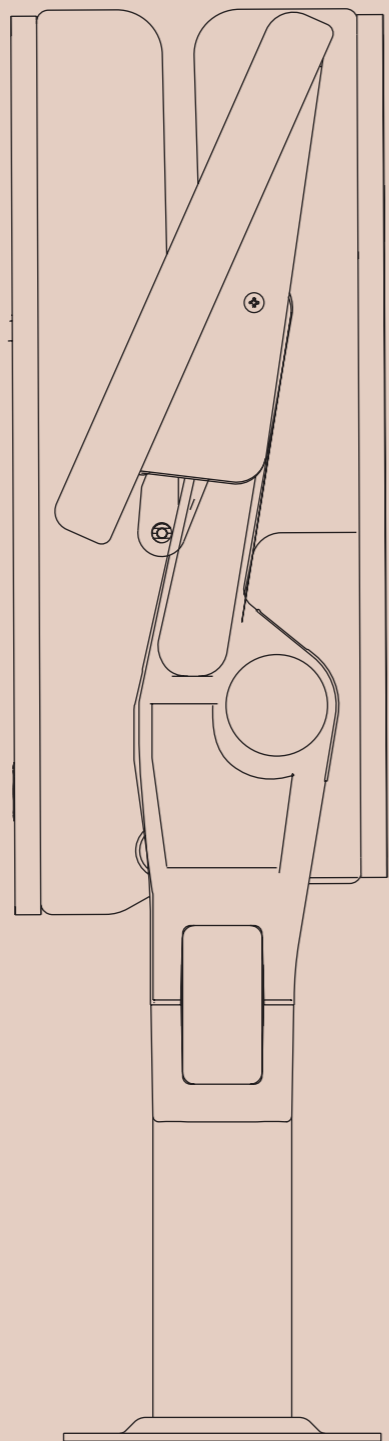

MINISPACE

5 0 7 2

MINISPACE

5072

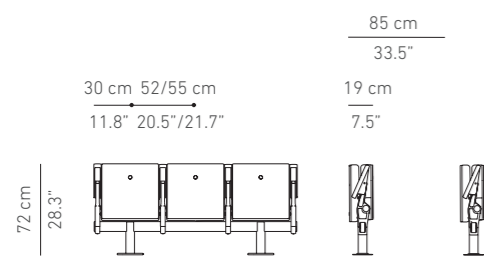

Minispace 5072



MINISPACE

5072



ACCESSORIES AND FINISHES / ACCESORIOS Y ACABADOS



Frontal view
Vista frontal



Row numbering
Seat numbering



Seat numbering
Numeración de asiento



PL Table
Mesa PL



R H O M B U S

C O L L E C T I O N

RHOMBUS

13037-58

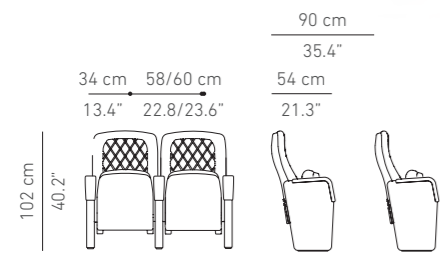

Rhombus 13037-58

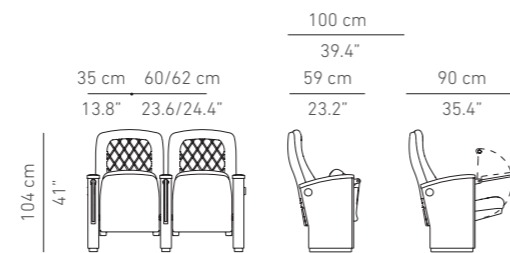

Rhombus 13037-60 PLX

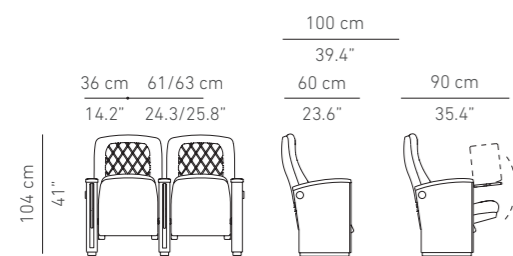

Rhombus 13037-60 APL

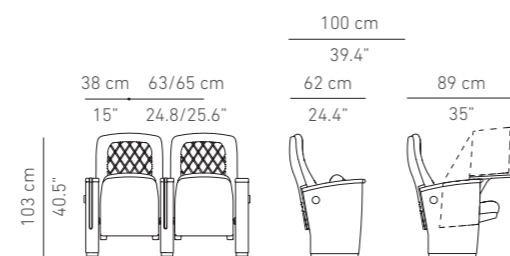

Rhombus 13037-63 GPL

RHOMBUS

13037-55

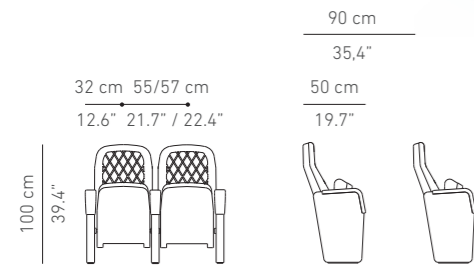

Rhombus 13057-55

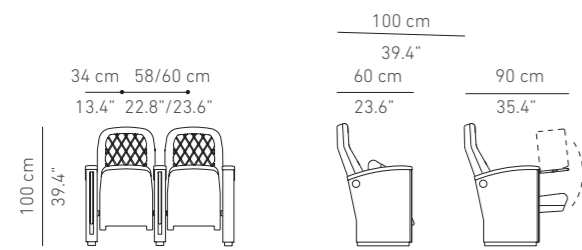

Rhombus 13037-58 APL

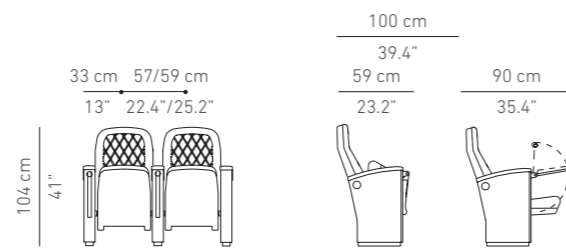

Rhombus 13037-58 PLX



RHOMBUS

13031-55

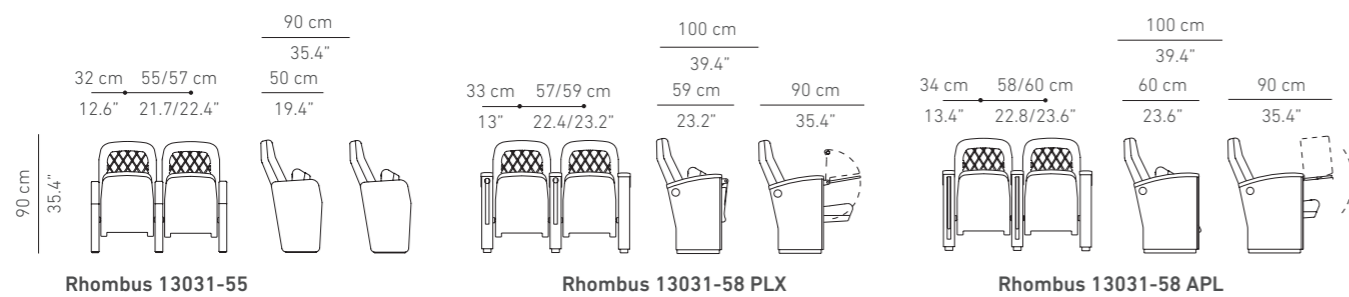

RHOMBUS

13031-55



4th Creative Party (Seoul, Korea)



ACCESSORIES AND FINISHES_ACCESORIOS Y ACABADOS



Upholstered backrest and seat. Row numbering
Respaldo y asientos tapizado. Numeración de fila



Armrest with wood finishing
Reposabrazos con acabados de madera



APL table integrated
Mesa APL integrada



GPL table integrated
Mesa GPL integrada

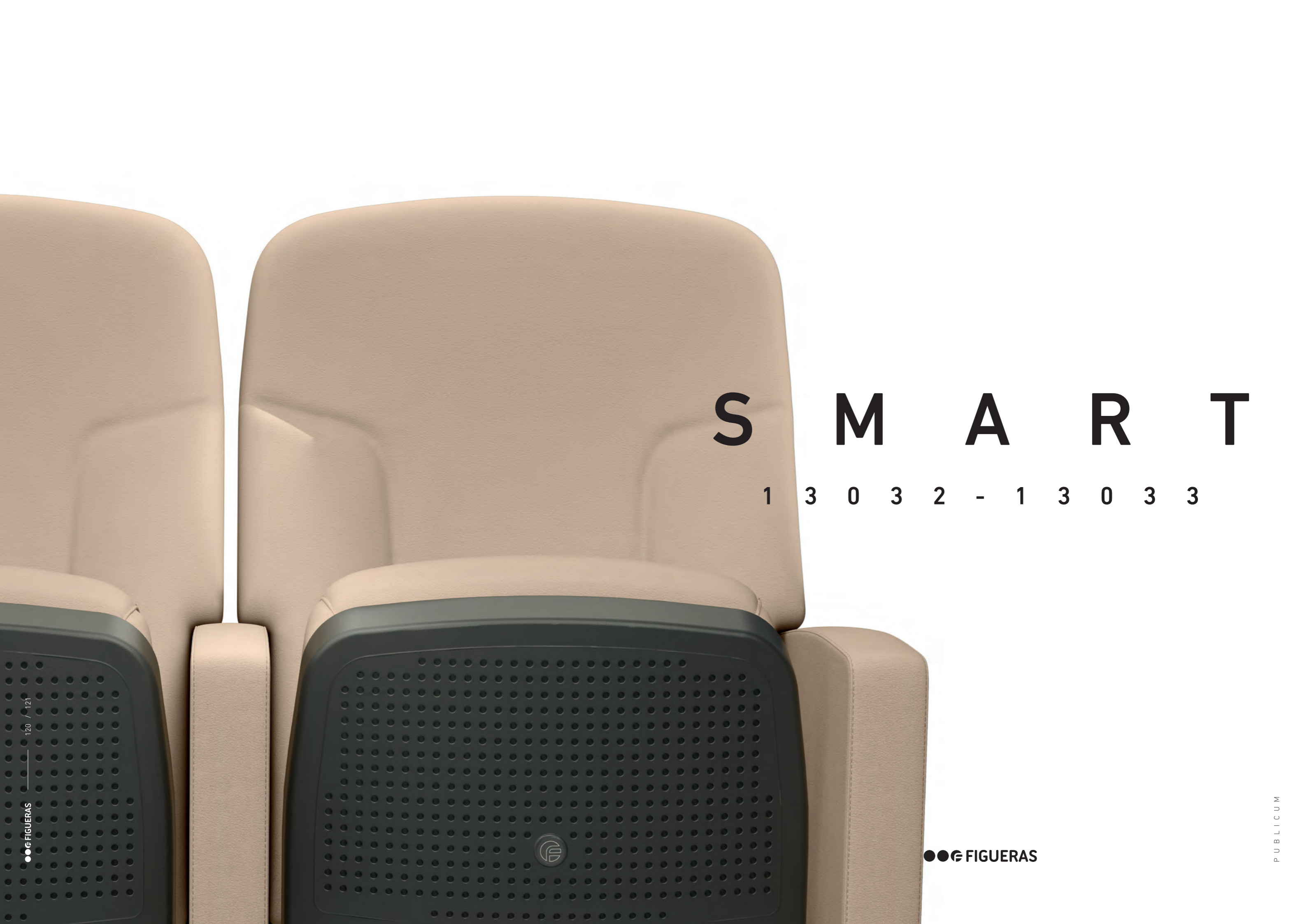

S M A R T

1 3 0 3 2 - 1 3 0 3 3

SMART

13032, 13033

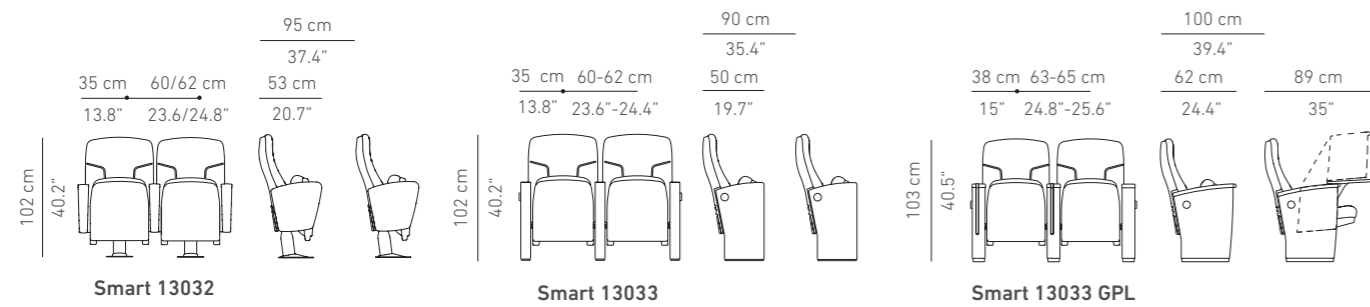

SMART

13032, 13033



Ahmanson Auditorium @ ArtCenter College of Design, University of Pasadena, Pasadena, CA, USA
Arch. Darin Johnstone Architects (DJA) – Photography: © Joshua White
Smart 13033



Fittler Club (Philadelphia, PA, USA)
Smart 13033



ACCESSORIES AND FINISHES_ACCESORIOS Y ACABADOS



Smart 13032 with upholstered seat and backrest
Smart 13032 con respaldo y asiento tapizados



Smart 13033 with side panels reaching the floor
Smart 13033 con costadillo hasta el suelo



Smart 13033 with partially upholstered backrest
Smart 13033 con cubeta trasera parcialmente tapizada



Smart 13033 with APL table
Smart 13033 con mesa APL



M E G A
8 1 3 6

MEGA

8136

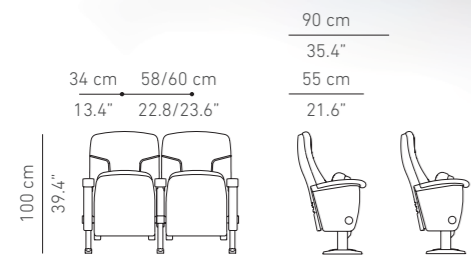

Megaseat 8136

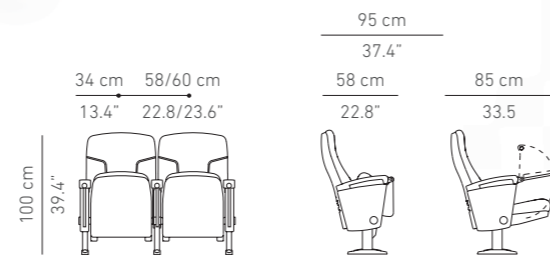

Megaseat 8136 PLX

MEGA

8136



Microsoft Auditorium (Reading, United Kingdom)
Arch. Pringle Brandon LLP Architects



Caisse Epargne (Metz, France)

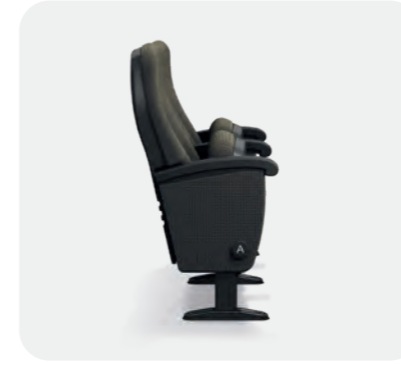

ACCESSORIES AND FINISHES / ACCESORIOS Y ACABADOS



Central pedestal
Pie central



Partially upholstered backrest
Cubeta trasera parcialmente tapizada



Seat numbering
Numeración de asiento



Shared armrest
Brazo compartido



Row numbering
Numeración de fila



PLX tablet
Mesa PLX



T O P

5 0 3 6

TOP

5036

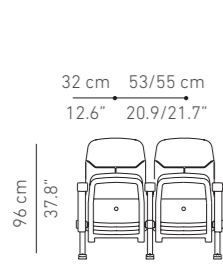

Top 5036

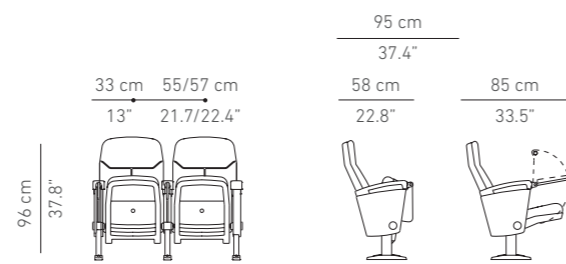
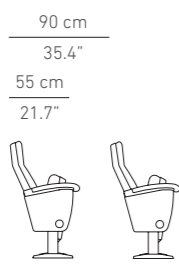

Top 5036 PLX

TOP

5036



Centre Culturel Emile Lahoud
(Beirut, Lebanon)



Musée des Confluences (Lyon, France) © Quentin Lafont
Arch. Coop Himmelb(l)au



Casal Riudomenc (Riudoms, Spain)



Médiathèque Landowski
(Boulogne Billancourt, France)

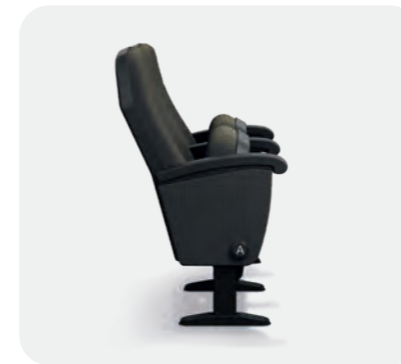

ACCESSORIES AND FINISHES_ACCESORIOS Y ACABADOS



Seat numbering
Numeración de asiento



Tip-up seat
Asiento abatible



Row numbering
Numeración de fila



PLX tablet
Mesa PLX



RT SYSTEM

C O L L E C T I O N

The right balance between movement and order

Free moving seat.

The body of the seat, fitted onto a floor-anchored pedestal, allows ease of rotation and movement.

Safety prioritised, providing room with neat and tidy image.

The seat returns to its original position when the user gets up.

El equilibrio entre movimiento y orden

Butaca de libre movimiento.

El cuerpo de la butaca permite movimientos de rotación y traslación sobre un pedestal fijo al suelo.

Seguridad e imagen siempre ordenada de la sala.

Cuando el usuario desocupa la butaca, esta recupera su posición original.

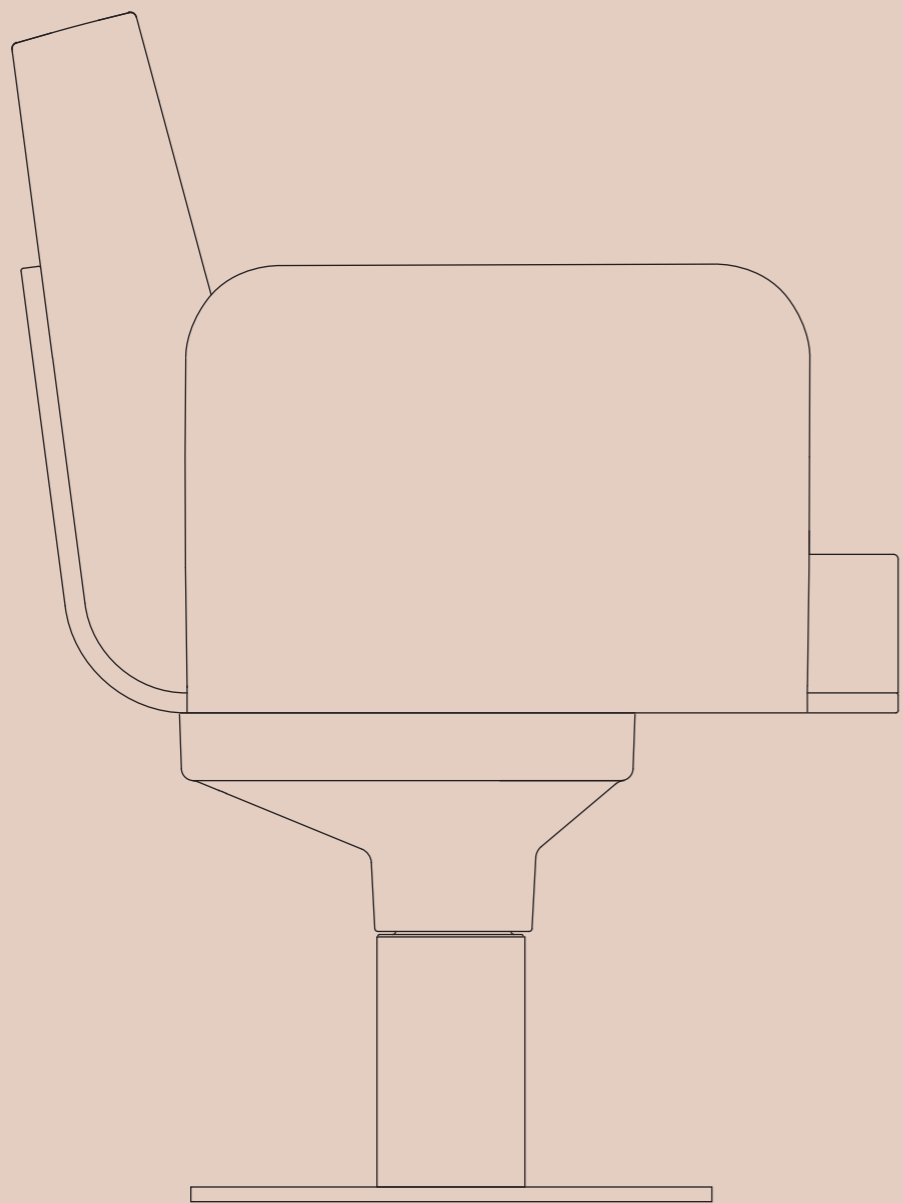

W O O D Y

R T 2 3 1 2 - S M

WOODY

RT2312-SM

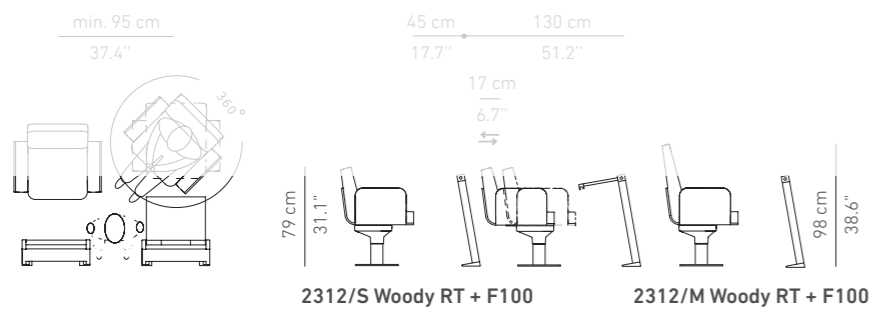

WOODY

RT 2312-SM



Symphony CaixaForum (Barcelona, Spain)
Arch. Torres-Grané Arquitectes



ACCESSORIES AND FINISHES_ACCESORIOS Y ACABADOS

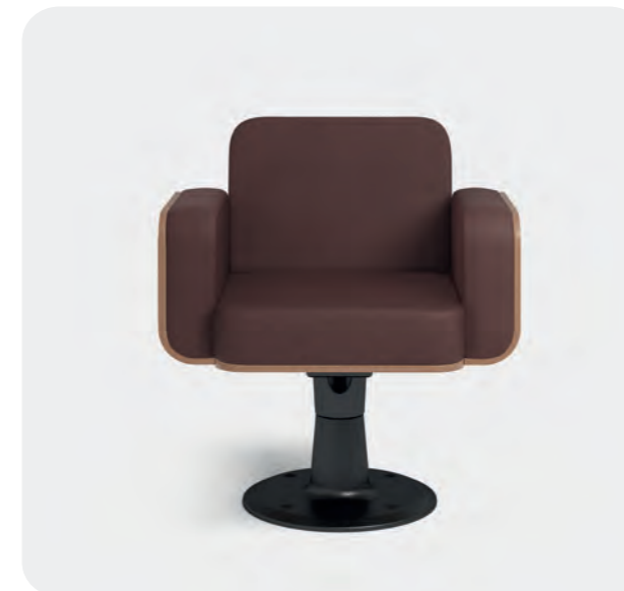

Woody RT 2312-S



RT system: simultaneous rotating and linear system
Sistema RT: sistema de rotación y lineal simultáneos

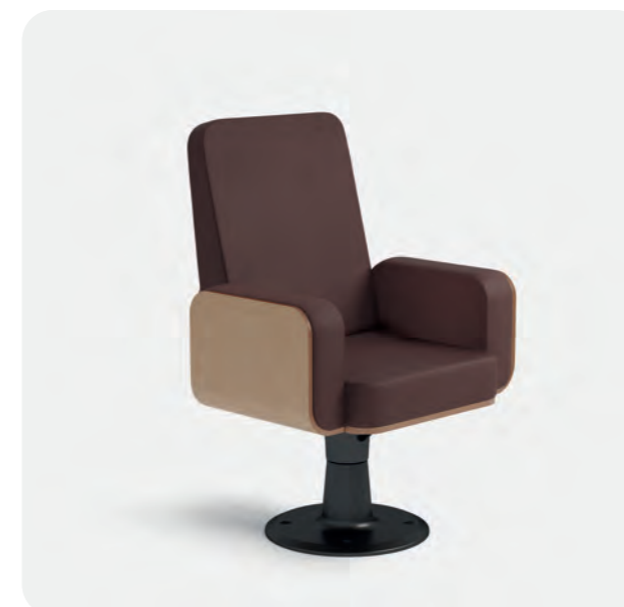

Woody RT 2312-M



Woody RT 2312-L

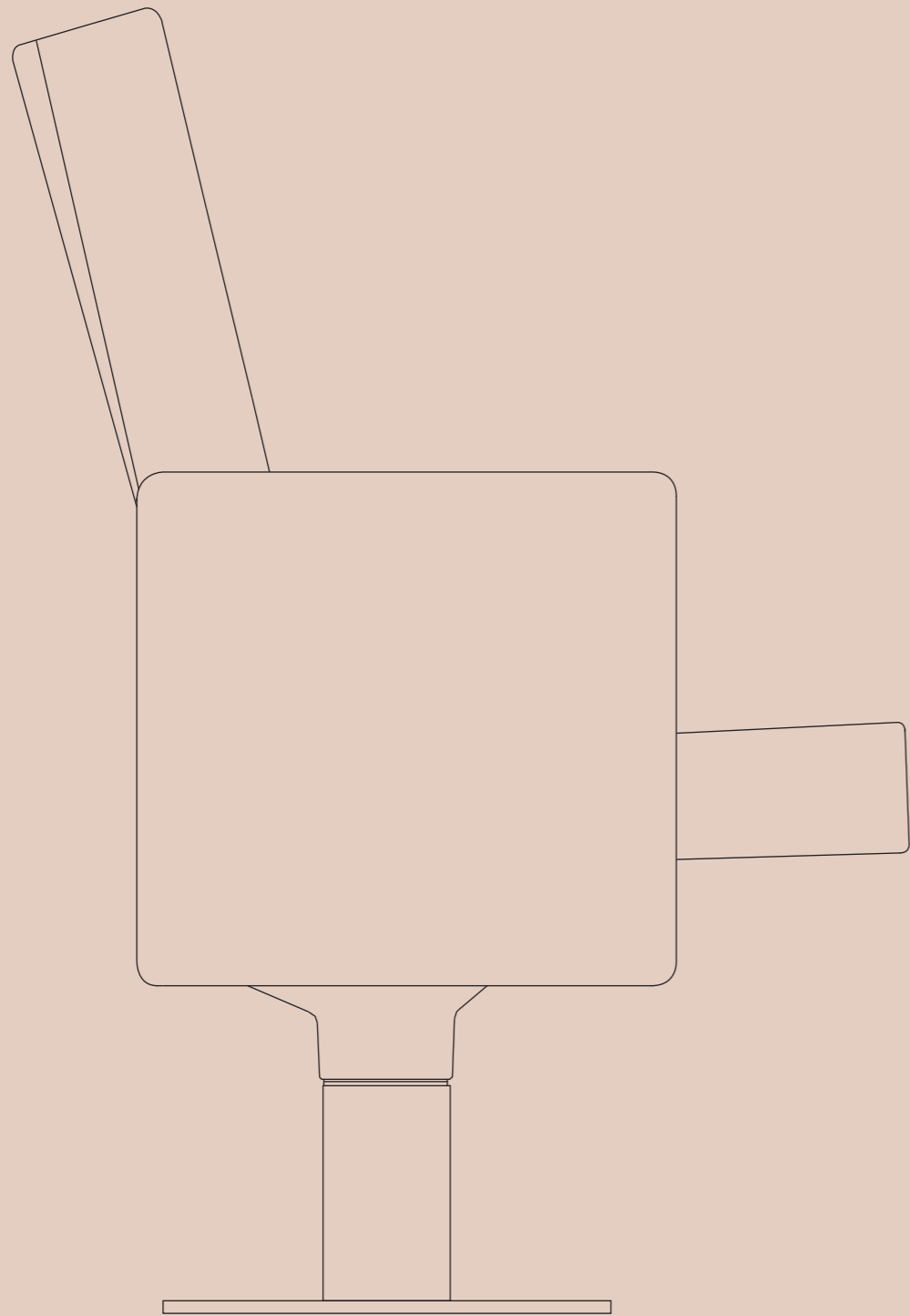

F L E X

R T 2 3 1 4

FLEX

RT 2314

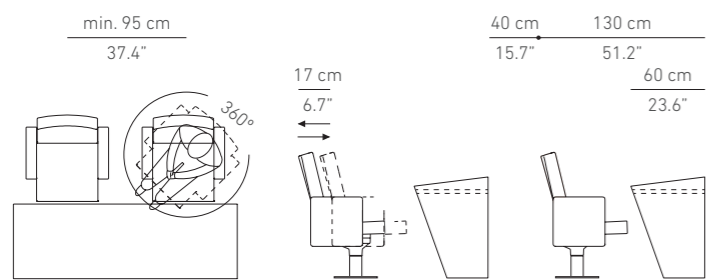

Flex 2314 RT System



FLEX

RT 2314



Consell General d'Andorra (Andorra la Vella, Andorra)
Arch. Artigues & Sanabria - Pere Espuga



Salle du Conseil du Doubs (Besançon, France)
Arch. Eric Poivey & Esther Barres



Bulgarian National Assembly (Sofia, Bulgaria)



Salle de Conferences de la Communauté de Communes
du Villefranchois (Villefranche-de-Rouergue France)
Arch. Jean Claude Bonnet & Étude Filiatre Mansour



ACCESSORIES AND FINISHES / ACCESORIOS Y ACABADOS



Front detail of the seat
Detalle frontal de la butaca



RT system: simultaneous rotating and linear system
Sistema RT: sistema de rotación y lineal simultáneos

PUBLICUM

SEATING COLLECTION

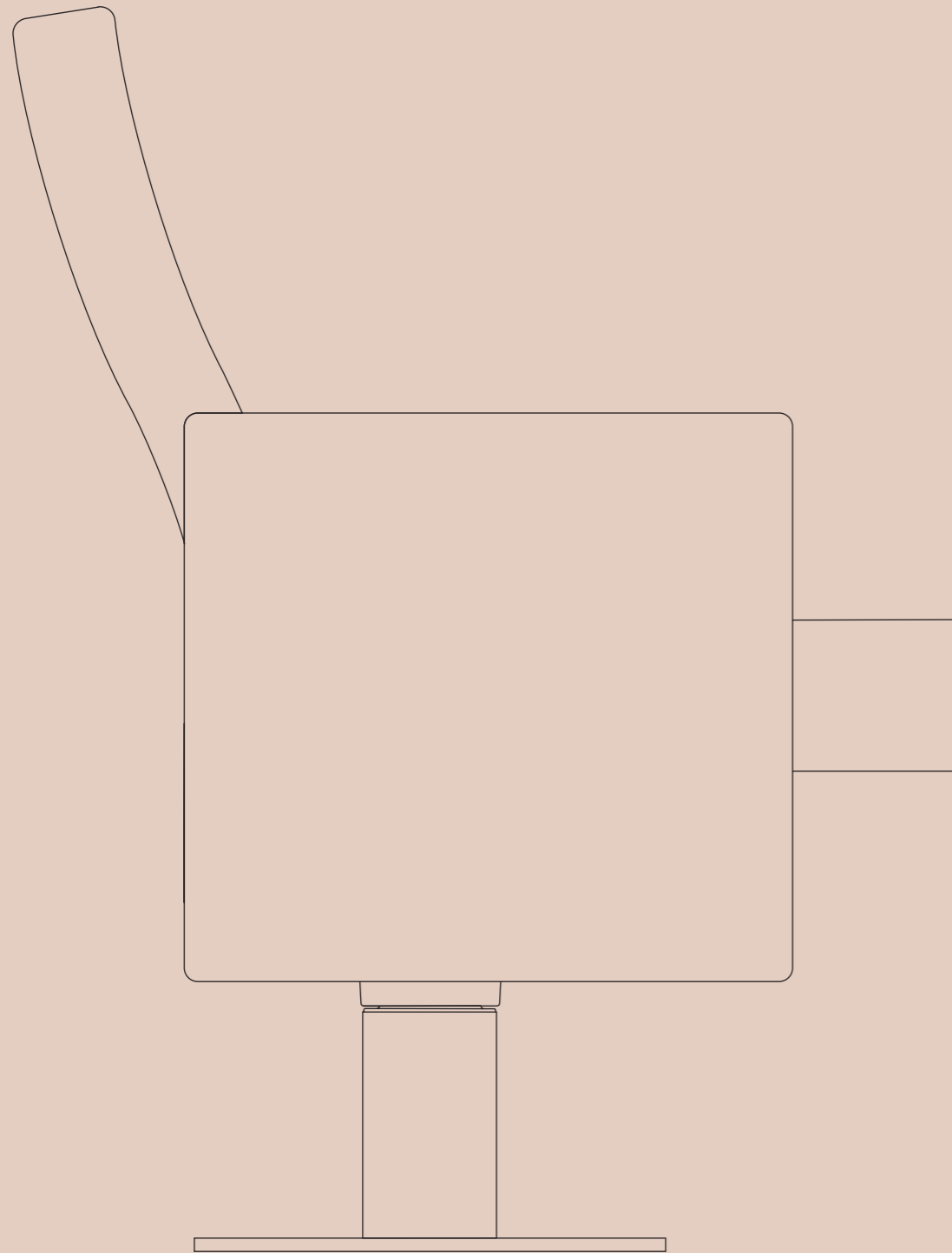

S E N S Ó

R T 2 3 1 3

SENSÓ

RT 2313

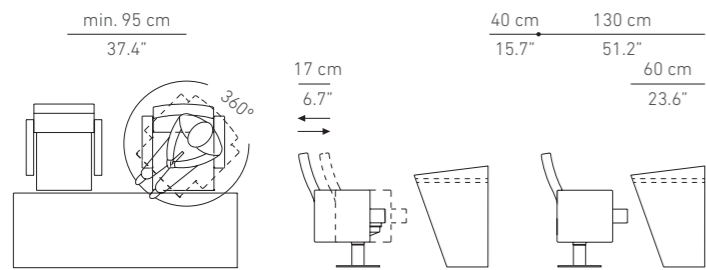

Sensó 2313 RT System



SENSÓ

RT 2313



Salle du Conseil, centre de congrès de l'Aube (Troyes, France)
Arch. José Ignacio Legazasoro



National Assembly of Cambodia
(Phnom Penh, Cambodia)



ACCESSORIES AND FINISHES / ACCESORIOS Y ACABADOS



Front detail of the seat
Detalle frontal de la butaca



Armrest in wood finishing
Brazo con acabado en madera



RT system: simultaneous rotating and linear system
Sistema RT: sistema de rotación y lineal simultáneos

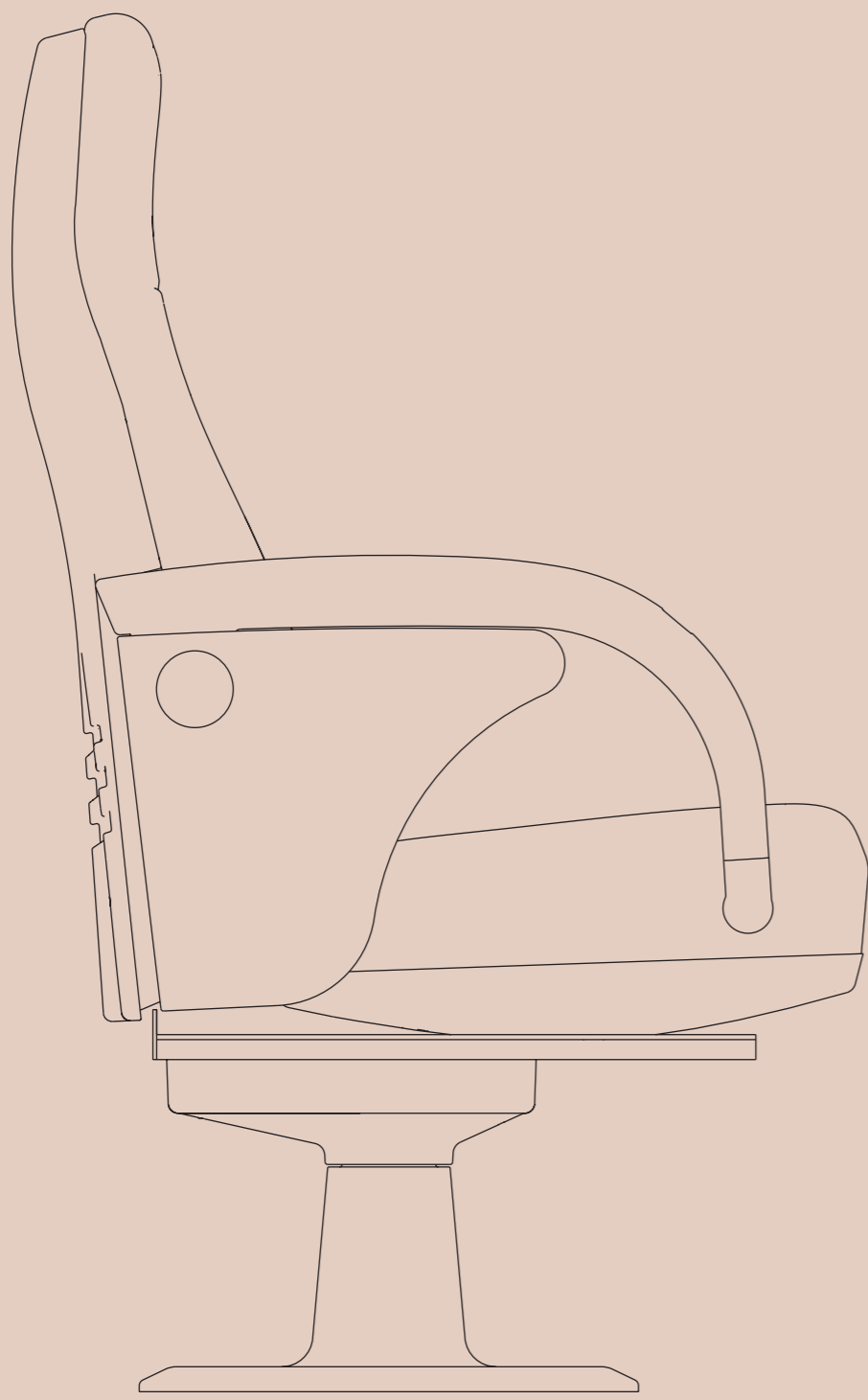

M E G A

R T 2 3 1 5

MEGA

RT 2315

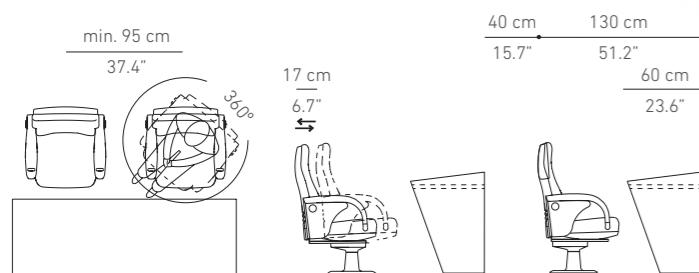

Megaseat 2315 RT System

MEGA

RT 2315



Senate – Red Chamber, National Assembly of Nigeria
(Abuja, Nigeria)



House of Representatives – Green Chamber, National Assembly of Nigeria
(Abuja, Nigeria)

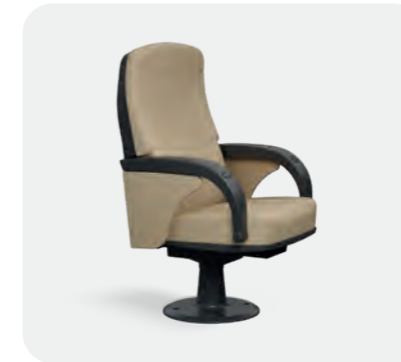

ACCESSORIES AND FINISHES / ACCESORIOS Y ACABADOS



Detail of the advanced position seat
Detalle de la butaca en posición avanzada



RT system: simultaneous rotating and linear system
Sistema RT: sistema de rotación y lineal simultáneos

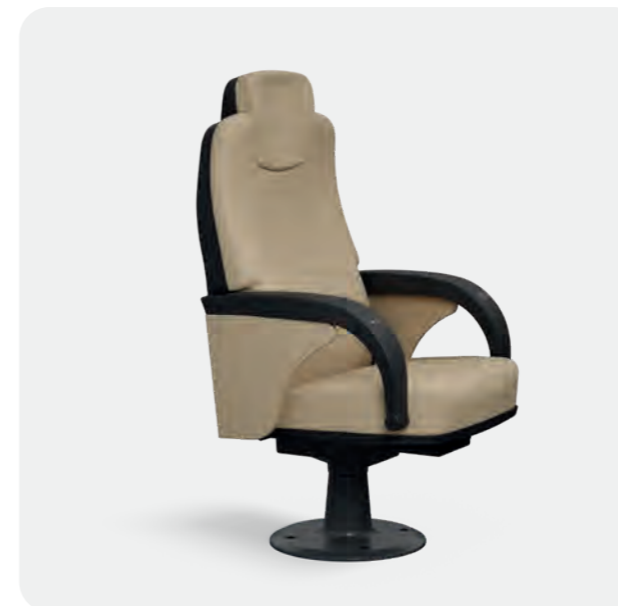

Mega RT 2315 with optional headrest
Mega RT 2315 con reposacabezas opcional



Seat numbering
Numeración de asiento



LOOSE SEATING

C O L L E C T I O N

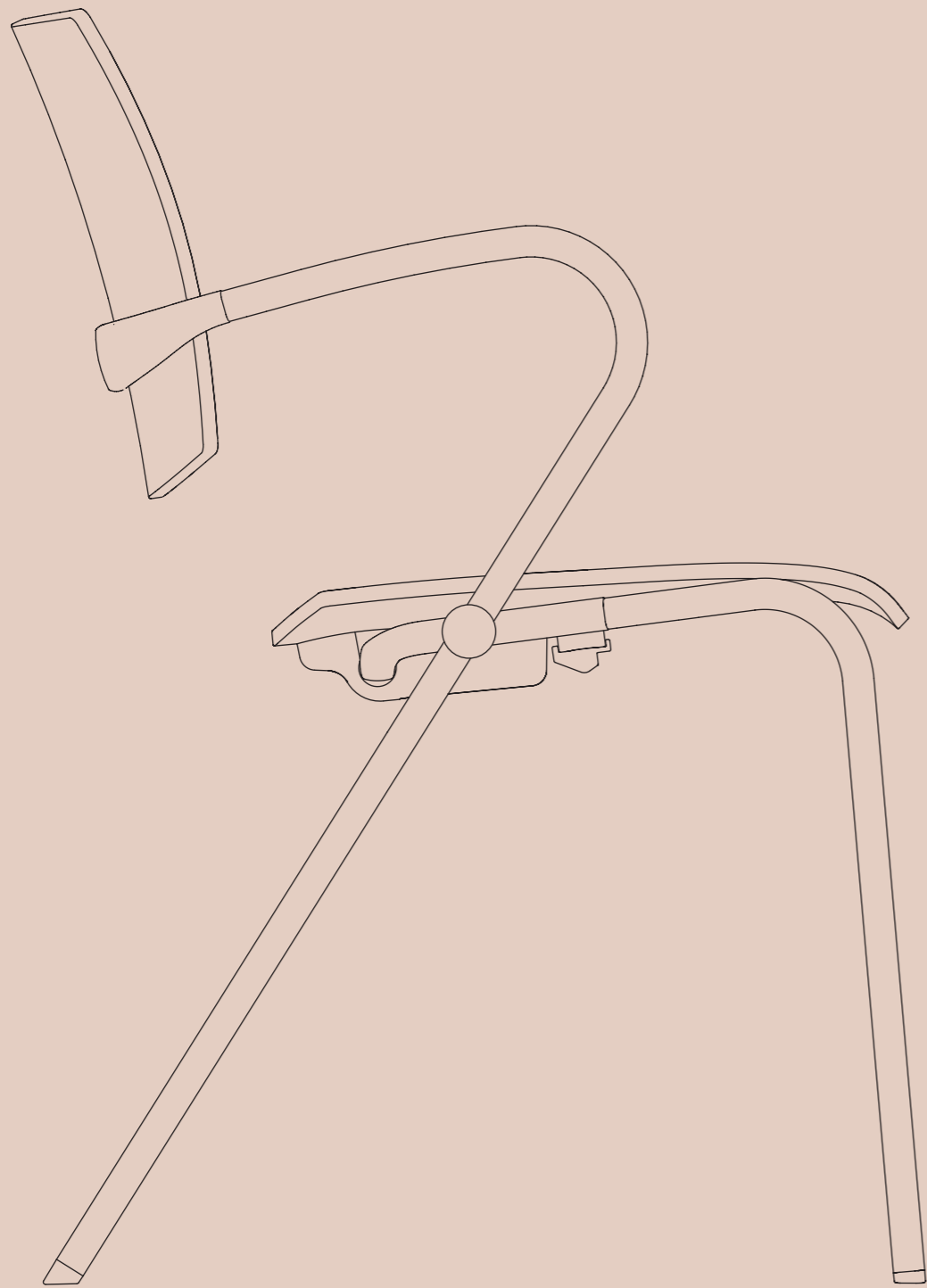

D E L T A

4 3 0 - 4 3 3

DELTA

430, 433

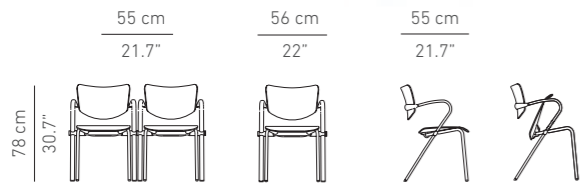

Delta 430

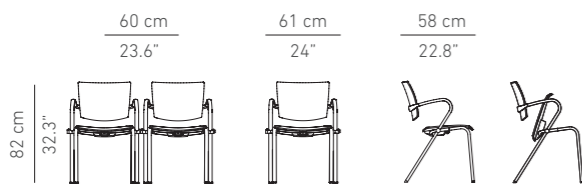

Delta Plus 430

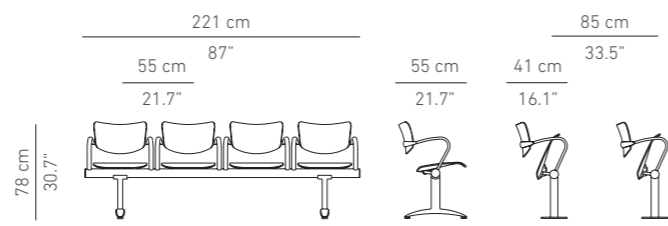

Delta Plus 433L

Delta Plus 433 FS



DELTA

430, 433



Zeitgeschichtliches Forum (Leipzig, Germany)



Auditorio Rosalba Pacheco (Bogotá, Colombia)



Mercabarna (Barcelona, Spain)



Medio.Rhein.Erft (Bergheim, Germany) ©Holger Rauner Arch. Busmann & Haberer GmbH Architekten



Delta 430



Delta Plus 430



Delta 433

ACCESSORIES AND FINISHES / ACCESORIOS Y ACABADOS



Row and seat numbering
Numeración de fila y silla



PLX tablet
Mesa PLX



Linking system
Enganche de unión entre sillas



Tip up seat
Asiento tip-up (plegable)



Central pedestal fixed to the floor
Pie central fijado al suelo



Freestanding side foot
Pie lateral autoestable



Transportation cart
Carrito para transporte

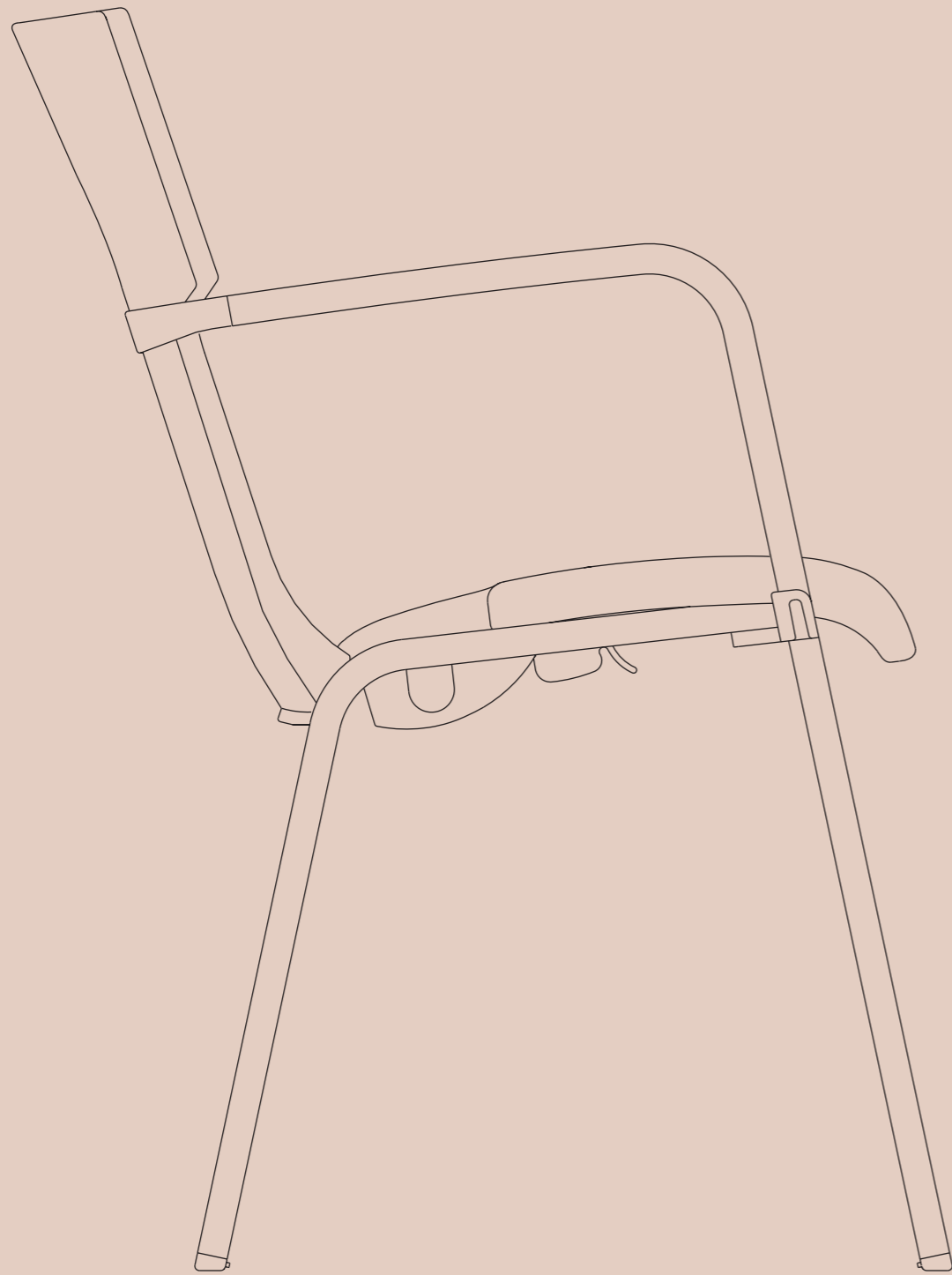

T U L I P A

TULIPA

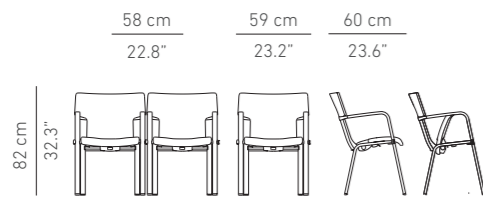

Tulipa 630

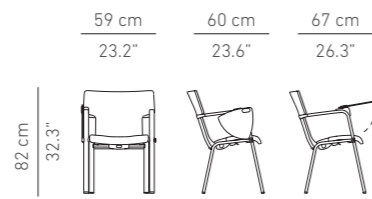

Tulipa 630 PL

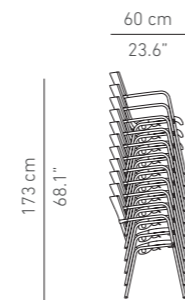

Stackabile
Apilable

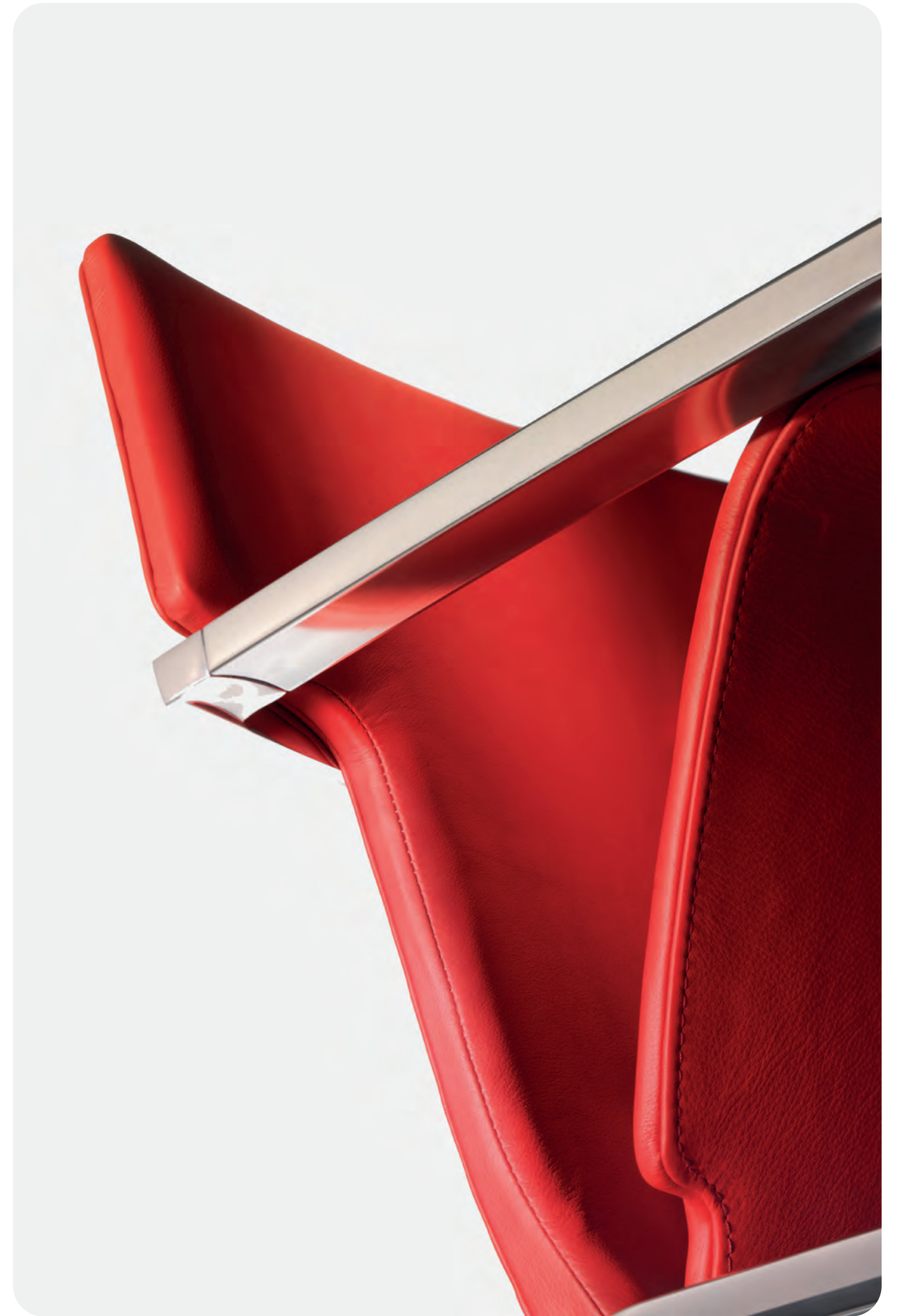

TULIPA



Institut Universitari Dexeus (Barcelona, Spain)
Arch. Ramon Sanabria, Lúdia Planas



ACCESSORIES AND FINISHES / ACCESORIOS Y ACABADOS



Row and seat numbering
Numeración de fila y silla



Tip up seat
Asiento abatible



Linking system
Enganche de unión entre sillas

REFERENCIAS_REFERENCES



Torre Diagonal One (Diagonal Zero Zero), (Barcelona, Spain)
 Arch. Enric Massip, EMBA Arquitectura
 Flex 6040



Groupe ADP (Paris, France)
 Arch. Bruno Cadorini
 Sensó 13113



National Library of Wales (Aberystwyth, Wales, UK)
 Minispace 5064



Zolotoy Duke (Odessa, Ukraine) ©Roland Halbe
 Arch. Legorreta® - Rogers Stirk Harbour + Partners
 Flex 6076



European Convention Centre (Luxembourg, Luxembourg)
 Arch. Architecture & Environnement
 Flex 6036



Auditorio Duval Pestana (Lagos, Portugal)
 Scala 148

REFERENCIAS_REFERENCES



Musée des Confluences (Lyon, France)
Arch. Coop Himmelb(l)au. ©Quentin Lafont
Top 5036



Vietnam National Assembly
(Hanoi, Vietnam) ©Christian Gahl
Sensó RT 2313



Palacio de Congresos de Córdoba (Córdoba, Spain) © LAP Arquitectos
Microflex 6061



RIA Novosti (Moscow, Russia) Arch. Georgui Trafimov
Flame 13107



BBVA Francés (Buenos Aires, Argentina)
Arch. Arquitectónica - BMA Arquitectos y Asociados - ESARQ
Flex 6035

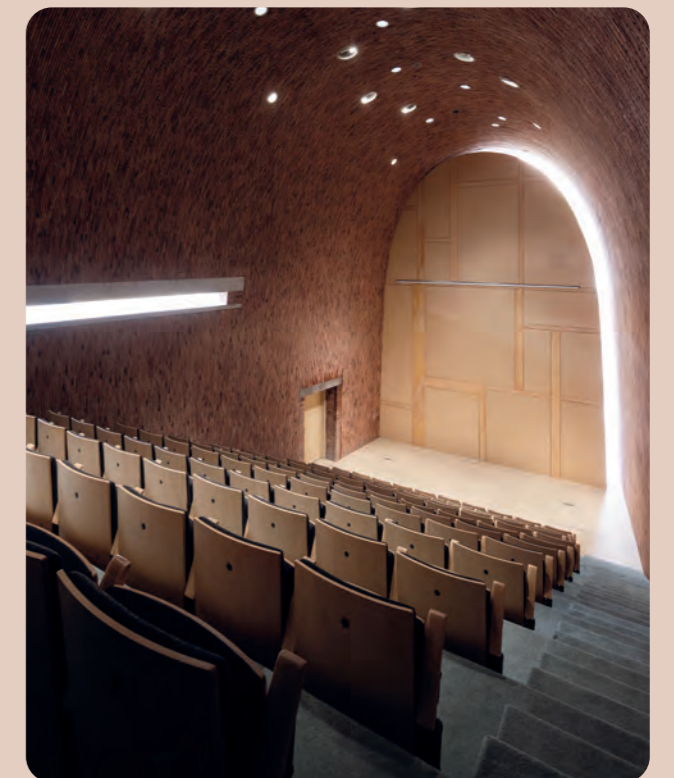

Jingdezhen Royal Kiln Museum, Jingdezhen (Jiangxi, China)
Arch. Studio Zhu-Pei
Minispace 5071

REFERENCIAS_REFERENCES



El Vicenç de la Mar (Cala Sant Vicenç, Mallorca, Spain)
Arch. Rafael Balaguer, Magnus Ehrland, Espacio Scena
Aptum 247



Centre Culturel Emile Lahoud (Beirut, Lebanon)
Smart 13032



Salle du Conseil du Doubs (Besançon, France)
Arch. Eric Poivey & Esther Barres
Flex 2314 RT



Çamlıca Mosque (Istanbul, Turkey)
Virtus 13205



MIT Cambridge, (Massachusetts, USA)
Arch. Ghery & Partners LLP
Minispace 5067

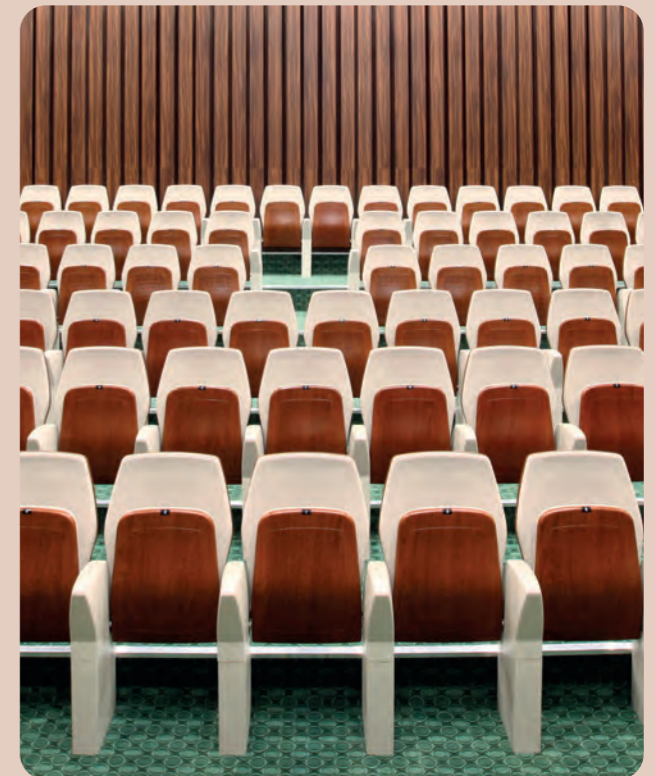



Bursa Chamber of Commerce (Bursa, Turkey)
Arch. Sözüneri Architecture
Lyon 13108

ACCESORIES_ACCESSORIES

	Connectivity Conectividad					Seat numbering Numeración asiento	Row numbering Numeración de fila	Illuminated row Fila iluminada
	Plugs Enchufes	USB	Voting system Sistema de votación (*)	Screens Pantallas	Lights Luces			
Flex 6035	■	■	■			■	■	■
Flex 6036	■	■	■	■	■	■	■	■
Flex 6076	■	■	■	■	■	■	■	■
Flex 6040 GPL	■	■	■	■	■	■	■	■
Flex 2314 RT	■	■ (**)				■	■	
Microflex 6061	■	■				■	■	■
Flame 13107					■	■	■	■
Sensó 13113	■	■	■	■	■	■	■	■
Sensó RT 2313	■	■	■	■		■	■	■
Lyon 13108					■	■	■	■
Scala 148	■	■	■	■	■	■	■	■
Virtus 13205	■	■ (**)	■	■	■	■	■	■
Minispace 5064	■	■ (**)				■	■	■
Minispace 5067	■	■ (**)				■	■	■
Minispace 5069	■	■ (**)				■	■	■
Minispace 5071	■	■ (**)				■	■	■
Minispace 5072	■	■ (**)				■	■	■
Minispace Fix 5064	■	■ (**)				■	■	■
Minispace Fix 5067	■	■				■	■	■
Woody RT 2312-S/M	■	■				■	■	
Aptum 246	■	■	■	■	■	■	■	■
Aptum 247	■	■			■	■	■	■
Aptum 248	■	■			■	■	■	■
Rhombus 13037-58	■	■	■	■	■	■	■	■
Rhombus 13037-55	■	■	■	■	■	■	■	■
Rhombus 13031-55	■	■	■	■	■	■	■	■
Smart 13032	■	■				■	■	■
Smart 13033	■	■	■	■	■	■	■	■
Mega 8136	■	■				■	■	
Mega RT 2315	■	■				■		
Top 5036	■	■				■	■	■
Delta 430 - 433						■	■	
Delta Plus						■	■	
Tulipa						■	■	

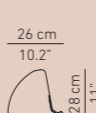
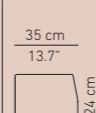
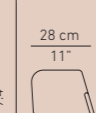
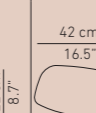
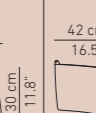
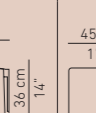
(*) Depending on size Dependende del tamaño
 (**) USB ports placed on the bar Los puertos USB van en la barra

	Writing Tablets & Tables Atriles y mesas							
	PL 	PLX 	APL 	A4PL 	A3PL 	GPL 	F48 	F1000 
Flex GPL 6040						■		
Flex 6036		■	■				■	■
Flex 6076				■	■		■	■
Flex 6035							■	■
Microflex 6061							■	■
Aptum 246							■	■
Aptum 247		■					■	■
Flame 13107		■					■	■
Scala 148		■					■	■
Sensó 13113		■	■				■	■
Lyon 13108		■					■	■
Virtus 13205				■	■		■	■
Minispace 5064	■						■	■
Minispace 5067	■						■	■
Minispace 5069							■	■
Minispace 5071	■						■	■
Minispace 5072	■						■	■
13037-58 Rhombus Star		■	■			■	■	■
13037-55 Rhombus Form		■	■				■	■
13031-55 Rhombus Corporate		■	■				■	■
Smart 13033		■	■			■	■	■
Smart 13032							■	■
Megaseat 8136		■					■	■
Top 5036		■					■	■
Delta 430 (*)		■						
Tulipa 630 (*)		■						

■ Optional_Opcional
 (*) The size and materials of this lectern for Delta and Tulipa chairs may vary slightly.
 El tamaño y los materiales de este atril para las sillas Delta y Tulipa puede variar ligeramente.

FINISHINGS_ACABADOS

	Armrests Brazos	PUR armrests Brazos en PUR	Wood side panels Costados de madera	Wood armrest Brazo de madera	Wood seat Asiento de madera
Flex 6035					■
Flex 6036			■	■	■
Flex 6076			■	■	■
Flex 6040 GPL			■		■
Flex 2314 RT			■	■	■
Microflex 6061					■
Flame 13107	■				
Sensó 13113	■		■	■	■
Sensó RT 2313			■	■	■
Lyon 13108					
Scala 148					
Virtus 13205			■	■	■
Minispace 5064		■		■	
Minispace 5067					
Minispace 5069				■	
Minispace 5071					
Minispace 5072					
Minispace Fix 5064					
Minispace Fix 5067				■	
Woody RT 2312-S/M					
Aptum 246			■		■
Aptum 247			■		■
Rhombus 13037-58		■		■	
Rhombus 13037-55		■		■	
Rhombus 13031-55		■		■	
Smart 13032					
Smart 13033			■	■	
Mega 8136				■	
Mega RT 2315					
Top 5036				■	
Delta 430 - 433					
Delta Plus					
Tulipa					

	Upholstered side panels Costados tapizados	Upholstered seat Asiento tapizado	Upholstered shell Cubeta tapizada	Upholstered backrest Respaldo tapizado	Upholstered armrest Brazos tapizados	Acoustic drilling Perforaciones acústicas	Decorative Stitching Costura decorativa	Headrest Reposacabeza
Flex 6035						■	■	
Flex 6036						■	■	
Flex 6076						■	■	
Flex 6040 GPL						■	■	
Flex 2314 RT							■	
Microflex 6061						■	■	
Flame 13107		■		■	■		■	
Sensó 13113					■	■	■	
Sensó RT 2313							■	
Lyon 13108								
Scala 148		■		■	■	■	■	
Virtus 13205				■		■	■	
Minispace 5064						■	■	
Minispace 5067					■		■	
Minispace 5069								
Minispace 5071			■				■	
Minispace 5072		■		■	■		■	
Minispace Fix 5064		■		■	■		■	
Minispace Fix 5067					■		■	
Woody RT 2312-S/M					■		■	
Aptum 246							■	
Aptum 247						■	■	
Rhombus 13037-58			■			■	■	
Rhombus 13037-55			■					
Rhombus 13031-55			■					■
Smart 13032			■					
Smart 13033			■					
Mega 8136			■					■
Mega RT 2315			■					■
Top 5036			■					
Delta 430 - 433		■		■				
Delta Plus		■		■				
Tulipa								

■ Optional_Opcional

SYSTEMS_SISTEMAS

Maximizing and optimizing the use of spaces in auditoriums, conference centers, and corporate rooms is our priority. We offer mobile seating systems that allow transforming any room for different uses, ensuring space optimization, flexibility, and profitability.

MOVABLE SEATING SOLUTIONS

Our systems, such as **Mutarail, Mutasub, and Mutawheel**, along with **retractable tribunes**, enable the conversion of any room into a multipurpose space. Within minutes, it is possible to reconfigure a room to adapt to all types of events, from conferences to product presentations.

CONSULTING AND EXPERIENCE

From the beginning of each project, the Figueras team works with clients to identify the most suitable engineering solutions. This collaboration ensures that each space is used in the most efficient manner, optimizing functionality and adaptability.

Our dedication to flexible and sustainable solutions has allowed us to establish lasting relationships worldwide, positioning Figueras Seating as a reference in the creation of transformable spaces:

Maximizar y optimizar el uso de espacios en auditorios, centros de conferencias y salas corporativas es nuestra prioridad. Ofrecemos sistemas de butacas móviles que permiten transformar cualquier sala para distintos usos, garantizando optimización del espacio, flexibilidad y rentabilidad.

SOLUCIONES DE BUTACAS MÓVILES

Nuestros sistemas, como **Mutarail, Mutasub y Mutawheel**, junto con **las gradas retráctiles**, permiten convertir cualquier espacio en una sala polivalente. En cuestión de minutos, es posible reconfigurar una sala para adaptarse a todo tipo de eventos, desde conferencias hasta presentaciones de productos.

ASESORÍA Y EXPERIENCIA

Desde el inicio de cada proyecto, el equipo de Figueras trabaja con clientes para identificar las soluciones de ingeniería más adecuadas. Esta colaboración asegura que cada espacio se utilice de la manera más eficiente, optimizando funcionalidad y adaptabilidad.

Nuestra dedicación a soluciones flexibles y sostenibles nos ha permitido establecer relaciones duraderas a nivel mundial, posicionando a Figueras Seating como un referente en la creación de espacios transformables:



MUTARAIL

Allows the sequential and individual movement of rows, storing the seats on one side or under the stage. Offers full, partial, or no seating configurations.

MUTASUB

This system stores the seats under the floor, creating an open space when not in use. It uses a steel structure covered with wood and a folding mechanism to store up to 12 seats per group and can be configured for sequential use.

MUTAWHEEL

Mounted on bars with multidirectional wheels, providing great versatility and easy placement. It does not require permanent attachment points and allows rows to be stored in storage spaces or along the back wall.

RETRACTABLE TRIBUNES

System in which seats can be extended, retracted, and stored in a wall or under the stage. Offers seating options with maximum flexibility and low maintenance, designed according to international standards.

With these solutions, Figueras Seating redefines flexibility and functionality in the design of transformable spaces, always ensuring maximum efficiency, quality, and sustainability.

MUTARAIL

Permite el movimiento secuencial e individual de las filas, almacenando las butacas en un lateral o debajo del escenario. Ofrece configuraciones de capacidad completa, parcial o sin butacas.

MUTASUB

Este sistema almacena los asientos debajo del suelo, creando un espacio diáfano cuando no se utilizan. Utiliza una estructura de acero cubierta de madera y un mecanismo de abatimiento para almacenar hasta 12 butacas por grupo, y puede ser configurado para ser usado secuencialmente.

MUTAWHEEL

Con las butacas montadas en barras con ruedas multidireccionales, proporciona gran versatilidad y fácil colocación. No requiere puntos de fijación permanentes y permite guardar las filas en espacios de almacenamiento o junto a la pared trasera.

GRADAS RETRÁCTILES

Sistema en el que los asientos pueden ser extendidos, replegados y almacenados en una pared o debajo del escenario, con una plataforma. Ofrece opciones de asiento con máxima flexibilidad y bajo mantenimiento, diseñado según normas internacionales.

Con estas soluciones, Figueras Seating redefine la flexibilidad y funcionalidad en el diseño de espacios transformables, garantizando siempre la máxima eficiencia, calidad y sostenibilidad.

SYSTEMS_SISTEMAS

Suitable seats for systems
Butacas aptas para sistemas



More technical info
Más información técnica

	Mutawheel	Mutarail	Mutasub	Retractable Tribune Grada Reetráctil	RT System Sistema RT	Gala System Sistema Gala
Flex 6035		■	■	■		
Flex 6036						
Flex 6076						
Flex 6040 GPL						
Flex 2314 RT					■	
Microflex 6061	■	■	■	■		
Flame 13107						
Sensó 13113						
Sensó RT 2313					■	
Lyon 13108						
Scala 148						
Virtus 13205						
Minispace 5064	■	■	■	■		
Minispace 5067	■	■	■	■		
Minispace 5069	■	■	■	■		
Minispace 5071	■	■	■	■		
Minispace 5072	■	■	■	■		
Minispace Fix 5064	■					
Minispace Fix 5067	■					
Woody RT 2312-S/M					■	
Aptum 246						
Aptum 247						
Rhombus 13037-58						
Rhombus 13037-55						
Rhombus 13031-55						
Smart 13032						
Smart 13033						
Mega 8136						
Mega RT 2315					■	
Top 5036						
Delta 430 - 433						
Delta Plus						
Tulipa						

■ Compatible with System_Apto para el sistema

MUTASUB

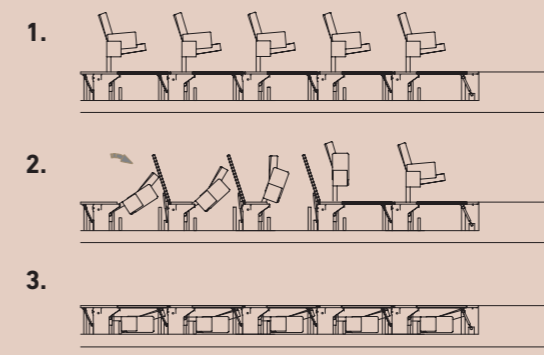

MUTARAIL

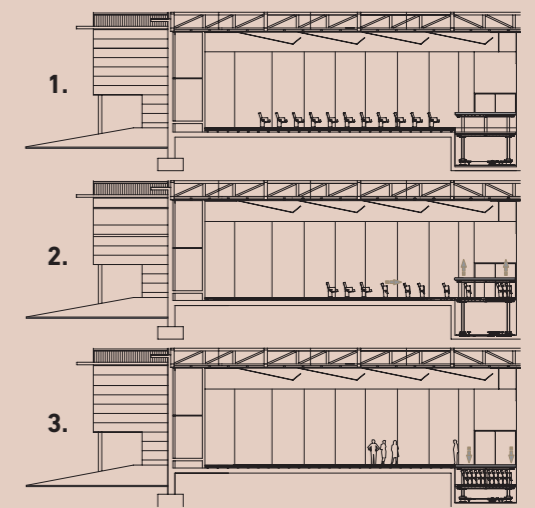

MUTAWHEEL

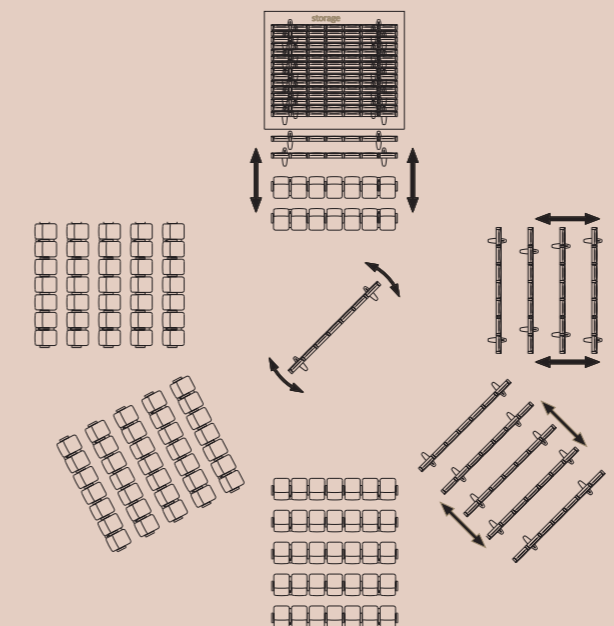

RETRACTABLE TRIBUNES_ GRADAS RETRÁCTILES

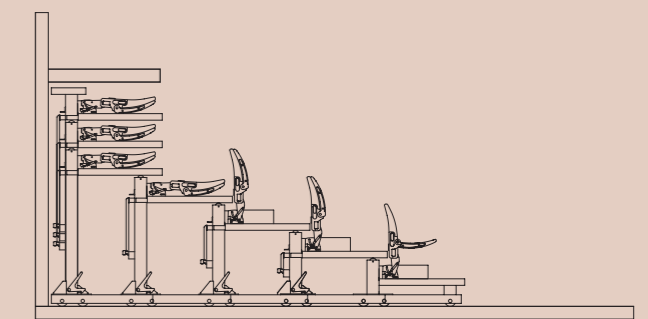

SERVICES

Figueras solutions go beyond the comfort of the seats, offering exceptional service and assistance.

At Figueras, we understand the importance of providing the best service to ensure your project's success.

We offer a wide range of services to ensure your auditorium's equipment is always in perfect condition. Our methodology includes:

PROJECT STUDY

Our team meets with you to determine the project's needs and review existing plans with your staff, architects, engineers, and contractors.

SELECTION AND EVALUATION OF SEATS

We select and propose the most suitable seats based on the specific needs of the project and advise you on choosing the most optimal options.

SELECTION OF FINISHES AND ACCESSORIES

We work to identify the necessary functional characteristics without neglecting the design. We select the appropriate type of fabric and finishing materials based on aesthetic criteria, level of use, and type of space.

LAYOUT DESIGN

Our designers and engineers determine the optimal number of seats and the best configuration to achieve maximum space optimization and functionality in accordance with general requirements and local regulations.

SIGHTLINES AND ACOUSTIC REQUIREMENTS

The seating layout is thoroughly evaluated to determine the optimal style, recommended width, and backrest height to ensure a perfect view for all users. Acoustic absorption requirements for each space are also assessed.

Las soluciones de Figueras van más allá de la comodidad de las butacas, con un servicio y una asistencia excepcionales.

En Figueras entendemos la importancia de proporcionar el mejor servicio para que tu proyecto sea un éxito.

Ofrecemos una amplia gama de servicios para garantizar que el equipamiento de tu auditorio esté siempre en perfectas condiciones. Nuestra metodología incluye:

ESTUDIO DEL PROYECTO

Nuestro equipo se reúne contigo para determinar las necesidades del proyecto y revisar los planos existentes con los miembros de tu equipo, arquitectos, ingenieros y contratistas.

SELECCIÓN Y EVALUACIÓN DE BUTACAS

Seleccionamos y proponemos las butacas más adecuadas en función de las necesidades específicas del proyecto y te asesoramos para escoger las opciones más óptimas.

SELECCIÓN DE ACABADOS Y ACCESORIOS

Trabajamos para identificar las características funcionales necesarias, sin descuidar el diseño. Seleccionamos el tipo de tejido adecuado y los materiales de acabado en función del criterio estético, el nivel de uso y el tipo de espacio.

DISTRIBUCIÓN

Nuestros diseñadores e ingenieros determinan el número óptimo de butacas y la mejor configuración de estas para lograr la máxima optimización del espacio y funcionalidad de acuerdo con los requisitos generales y la normativa local.

LÍNEAS DE VISIÓN Y REQUISITOS ACÚSTICOS

Se evalúa detalladamente la distribución de las butacas en el espacio para determinar el estilo, la anchura recomendada y la altura del respaldo más adecuada para garantizar una visión perfecta para todos los usuarios. También se evalúan los requisitos de absorción acústica óptimos para cada espacio.

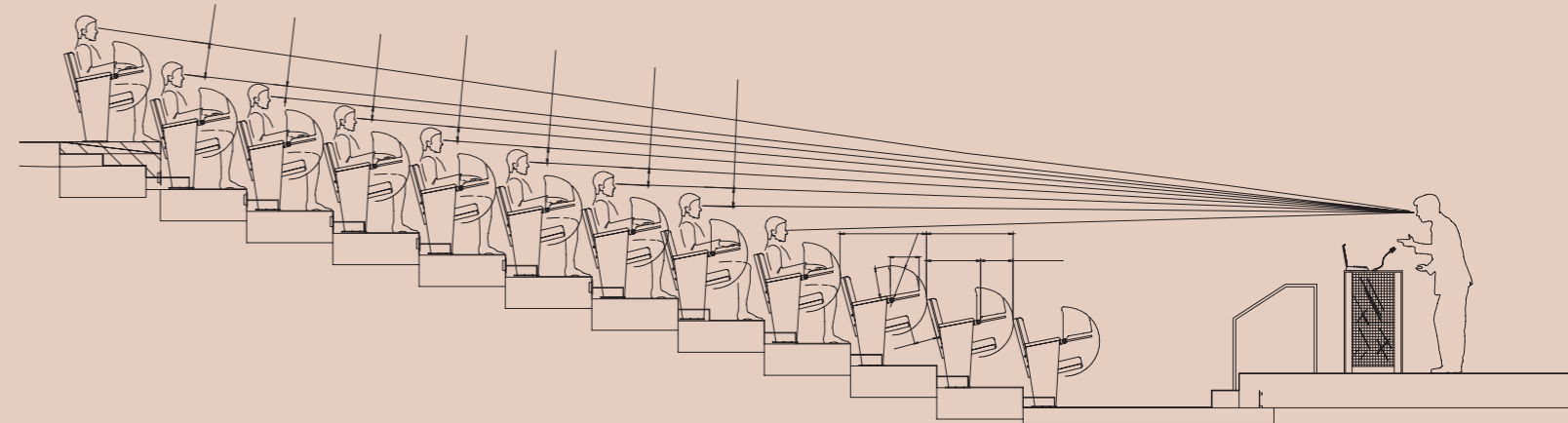

PROJECT PLANNING

Our team plans every detail of the project, from manufacturing to delivery and installation of the seats, to ensure a flawless procedure.

QUALITY CONTROL & WARRANTIES

Our seats undergo rigorous control processes at every stage of the project to ensure the highest quality. We hold ISO 9001, 14001, and 14006 certifications, providing peace of mind to our clients.

DELIVERY AND INSTALLATION

With over 95 years of experience in the sector and a proven track record of exporting and installing seats in more than 130 countries worldwide, we guarantee fast delivery and hassle-free installation.

SPARE PARTS AND REFURBISHMENT

We offer spare parts and refurbishment services to ensure the correct functioning of the seats over the years. We can help identify and obtain the necessary parts, as well as renew and reupholster existing seats to extend their lifespan.

PLANIFICACIÓN DEL PROYECTO

Nuestro equipo planifica cada detalle del proyecto, desde la fabricación hasta la entrega e instalación de las butacas, para garantizar un procedimiento perfecto.

CONTROL DE CALIDAD Y GARANTÍAS

Nuestras butacas se someten a rigurosos procesos de control en cada fase del proyecto para garantizar la máxima calidad. Contamos con las certificaciones ISO 9001, 14001 y 14006, lo que proporciona tranquilidad a nuestros clientes.

ENTREGA E INSTALACIÓN

Con más de 95 años de experiencia en el sector y un historial probado de exportación e instalación de butacas en más de 130 países de todo el mundo, garantizamos una entrega rápida y una instalación sin complicaciones.

PIEZAS DE REPUESTO Y REACONDICIONAMIENTO

Ofrecemos piezas de repuesto y servicios de reacondicionamiento para asegurar el correcto funcionamiento de las butacas durante años. Podemos ayudar a identificar y obtener las piezas necesarias, así como a renovar y retapizar las butacas existentes para prolongar su vida útil.

●●  FIGUERAS

LADIES &
GENTLEMEN