



Megaseat 9112

Technical specifications

› Structure

- Made of tube and steel plate arc welding with continuous wire.

› Paint

- Electrostatic powder polyester paint.
- Paint Thickness: 70-80 microns.
- Grid adhesion according to UNE-EN ISO 2409 : 100%.

› Upholstery

- Reaction to fire standards:
 - Spain: UNE-EN 1021 Parts 1 and 2.
 - France: NF D 60-013.
 - Italy: UNI 9175 Class 1.IM.
 - Germany: DIN 66084.
 - USA: CAL TB117.

› Polyurethane foam

- Seat density: 60-65Kg/m³.
- Backrest density: 50-55Kg/m³.

› Polypropylene

- Material: Polypropylene Copolymer IF-727.
- Tensile strength according to ISO 527-2: 26 Mpa.
- Elasticity module according to ISO 527-2: 1250 Mpa.

› Fire resistance

- BS 5852. Clause12. Ignition sources 0,1 and 5. (with approved fabric).
- USA:CAL T.B. 133 (with approved fabric).

› Resistance and durability classification

- UNE-EN 12727 Level 4 (Severe use).

General dimensions

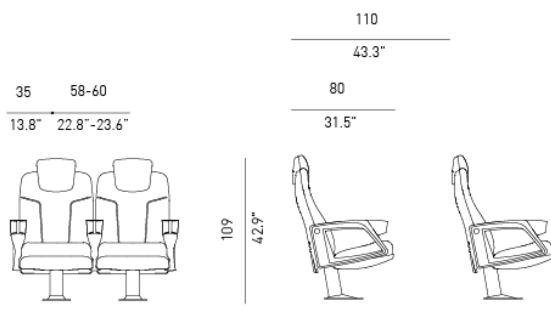

Megaseat 9112

However, for the purpose of facilitating to the customer the latest novelties, FIGUERAS reserves the right to introduce the modifications and variations that it considers most appropriate and suitable for marketing its products.

General Description

› Modular seat of high comfort and large dimensions, designed for use in VIP lounges, cinemas or Home Cinema rooms.

· The seat is mounted on a central foot attached to an internal connecting bridge that interconnects the different seats and allows the formation of totally rigid and stable rows. The feet are made of tubular steel structure finished in black or grey polyester paint.



· The seat and backrest are composed of two blocks of moulded polyurethane foam, with a metal interior structure and upholstery fully integrated into the foam by means of the Integral Form system, without seams or stitching.

· The seat adapts to the specific slope of the room through the foot base. The rows are formed by interconnected backrests and allow the formation of totally rigid and stable rows, reinforcing the fixation to the floor.

· The armrests are made of polyurethane foam, with an internal metal structure, incorporating an integrated cup holder in a compact, one-piece form. Optionally, the backrest can incorporate a piece of upholstery in the upper back. The seat can also be fully upholstered.



· The seat is fixed, always in the open position. The minimum wheelbase is 58 cm nominal value. This distance is not achieved by adding wider arms or supplements between the seats, but by increasing the dimensions of the seat and backrest, so that the real width of the backrest is 56 cm, a measure that provides a high level of comfort.



· Between the upholstery and the foam, both in the seat and in the backrest, there is a fire curtain or -TS System-. This curtain prevents the fire from penetrating into the foam, delaying the emission of toxic gases and the spread of flames.

· The backrest cushion is ergonomically designed, with lumbar support and headrest, incorporating vertical and horizontal channels in the part of the headrest.

· The backrest can also be made with HR finishing. This type of backrest is composed of a headrest that is integrated into the whole backrest, i.e. it's not added to the backrest but is part of it. This headrest system provides a clear ergonomic advantage as it becomes a natural extension of the backrest, not an accessory element added to it.

· The seat cushion is anatomically shaped and smooth, without any type of channel or groove to avoid dirt accumulation. The seat and backrest are protected by fully washable material finishings that protect the upholstery on the back.

However, for the purpose of facilitating to the customer the latest novelties, FIGUERAS reserves the right to introduce the modifications and variations that it considers most appropriate and suitable for marketing its products.

Functional Description

› Medium table

- Plastic injection table with rotation mechanism.
- 44 oz. Cupholder included.
- Pad with Rugged non-slip upper surface.

› Small table

- Plastic injection table with rotation mechanism.
- 44 oz. Cupholder included
- Rugged non-slip upper surface

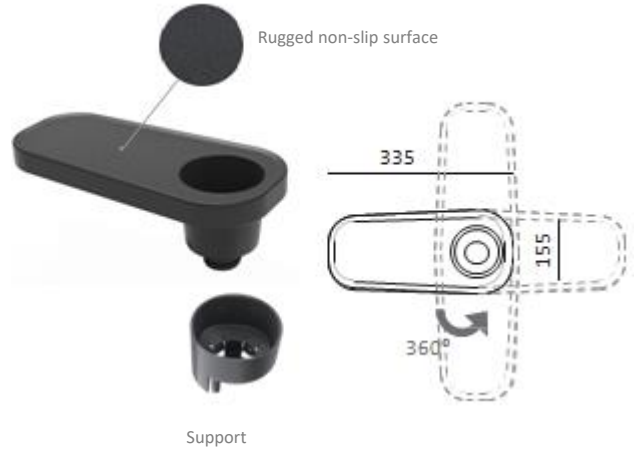

However, for the purpose of facilitating to the customer the latest novelties, FIGUERAS reserves the right to introduce the modifications and variations that it considers most appropriate and suitable for marketing its products.

However, for the purpose of facilitating to the customer the latest novelties, FIGUERAS reserves the right to introduce the modifications and variations that it considers most appropriate and suitable for marketing its products.

Materials and finishes

› Metal Parts Features

- The steel complies with the following European standards:
 - Tube up to 2mm thick: Alloy designation according to UNE-EN 10305 part 3: E-220.
 - Tube more than 2 mm thick: Alloy designation S275JR.
 - Plate: alloy designation according to EN 10111: DD12.

› Protection and Paint of Metal Parts

- Prior to powder coating, metal parts are treated with a three stage, non-acidic cleaning process to achieve superior finish adhesion. The finishing of the thermosetting polyester powder coating must be applied by electrostatic means with a minimum thickness of 70-80microns.
 - After coating, the parts must be oven cured to create a durable finishing that meets the following requirements:
 - Composition: Polyester powder suitable for outdoor use.
 - Cross Cut Test Adhesion according to UNE-EN ISO 2409 classification GT 0-1.
 - Scratch resistance according to ISO 15184:98 Level HB-H.
 - Total thickness: 70-80Microns.
 - Rust resistance (NSS), according to ISO 9220: 200 h.
 - Resistance to MEK 50 double rubs without paint stripping.

› Plastic parts features

- High pressure injection moulded seat and backrest shells made of high impact copolymer polypropylene. High durability pigmented coloured plastic with textured exposed surface.

› Upholstery

• Integral Form / Traditional

• Group A:

Figueras Fabrics ®

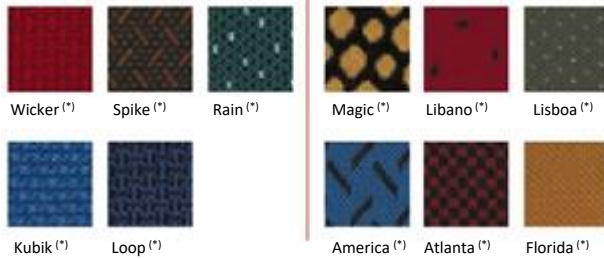

• Group B:



• Group V:



• Only Traditional

• Group A:

Figueras Fabrics ®



• Group B:

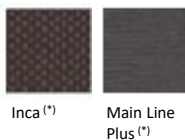

• Group L:

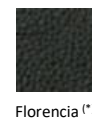

(*) Fabric sample / printed by collection. Check colours available.

(*) Quotation for traditional upholstery upon request.

› Pigments for plastic parts



› Tecnowood finishes for plastic parts

