



Smart Fix 13010

Technical specifications

Structure

- Made of tube and steel plate arc welding with continuous wire.

Polyurethane foam

- Seat density: 60-65 Kg/m³.
- Backrest density: 50-55 Kg/m³.

Paint

- Electrostatic powder polyester paint.
- Paint Thickness: 70-80 microns.
- Grid adhesion according to UNE-EN ISO 2409 : 100%.

Upholstery

- Reaction to fire standards:
 - Spain: UNE-EN 1021 Parts 1 and 2.
 - France: NF D 60-013.
 - Italy: UNI 9175 Class 1.IM.
 - Germany: DIN 66084.
 - USA: CAL TB117.

Leather

- Adhesion to finish according UNE-EN ISO 11644: >2.5 N/cm²
- Resistance to rubbing according UNE-EN ISO 11640: (Dry, 1.000 Cycles) >4

Polypropylene

- Material: Polypropylene Copolymer IF-727.
- Tensile strength according to ISO 527-2: 26 Mpa.
- Elasticity module according to ISO 527-2: 1250 Mpa.

Fire resistance

- BS 5852. Clause12. Ignition sources 0,1 and 5. (with approved fabric).
- USA:CAL T.B. 133 (with approved fabric).

Resistance and durability classification

- UNE-EN 12727 Level 4 (Severe use).

General dimensions

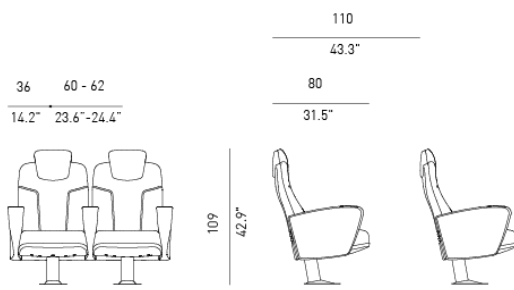

Smart Fix 13010

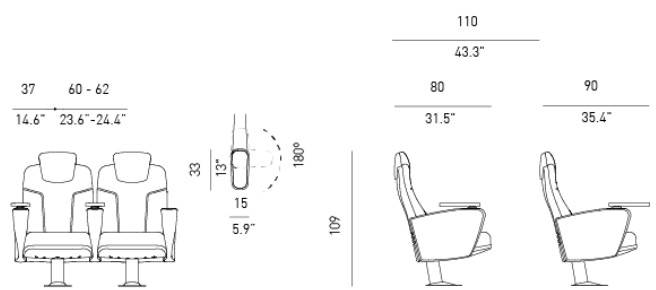

Smart Fix 13010 + Table

General Description

› Modular seat of high comfort, of fixed back and large dimensions, designed to be used in high level VIP rooms, cinemas, or Home Cinema rooms.



· The seat and backrest are made up of two blocks of moulded polyurethane foam, with a metal interior structure incorporated and upholstery fully integrated into the foam through the Integral Form system, without any seams or stitching (with the exception of seats upholstered in leather). The Integral Form system guarantees an exact piece to the original in case of replacement.



· The backrest is fixed. The backup can also be carried out in HR configuration. This type of backrest is characterized by incorporating a headrest that is integrated into the whole backrest. This headrest system provides a clear ergonomic advantage as it becomes a natural extension of the backrest.

· Between the upholstery and the foam, both in the seat and in the backrest, a fire curtain -TS System- can be incorporated to prevent the fire from penetrating into the foam, delaying the emission of toxic gases and the spread of flames.

· The backrest cushion is ergonomically shaped with vertical and horizontal channels at the top of the backrest. The seat cushion defines an ergonomic and smooth shape, without any type of channel or grooves to avoid the accumulation of dirt.

· The seat and backrest have are made of washable polypropylene, thus avoiding rubbing or dirt from the upholstery on the back part. Optionally, the backrest tray can be totally or partially upholstered to match the mattresses. The seat is always open.



· The seat is assembled on a central foot attached to an internal connecting bridge that interconnects the different seats and allows the formation of totally rigid and stable rows. Both the foot and the bridge are made of tubular steel structure finished in polyester paint. The seat adapts to the specific slope of the room at the base of the foot.

· The armrests, made of blown plastic, are always upholstered and incorporate an integrated cup holder in a compact, one-piece form.



However, for the purpose of facilitating to the customer the latest novelties, FIGUERAS reserves the right to introduce the modifications and variations that it considers most appropriate and suitable for marketing its products.

However, for the purpose of facilitating to the costumer the latest novelties, FIGUERAS reserves the right to introduce the modifications and variations that it considers most appropriate and suitable for marketing its products.

Functional description

› Medium table

- Plastic injection table with rotation mechanism.
- 44 oz. Cupholder included.
- Pad with Rugged non-slip upper surface.

› Small table

- Plastic injection table with rotation mechanism.
- 44 oz. Cupholder included
- Rugged non-slip upper surface

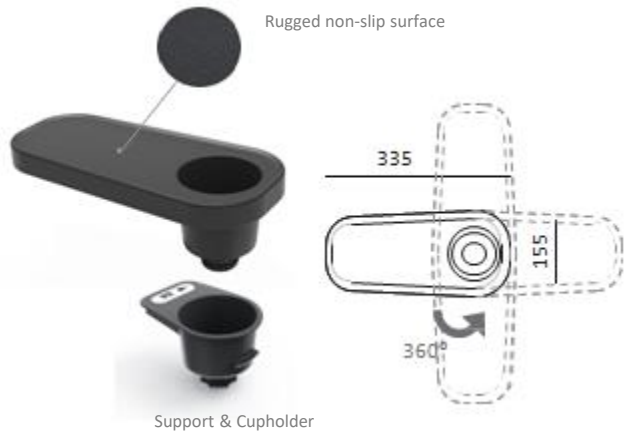
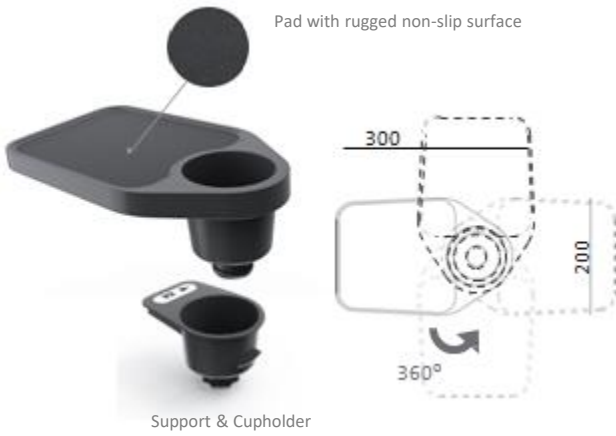

However, for the purpose of facilitating to the customer the latest novelties, FIGUERAS reserves the right to introduce the modifications and variations that it considers most appropriate and suitable for marketing its products.

Materials and finishes

› Metal Parts Features

- The steel complies with the following European standards:
 - Tube up to 2mm thick: Alloy designation according to UNE-EN 10305 part 3: E-220.
 - Tube more than 2 mm thick: Alloy designation S275JR.
 - Plate: alloy designation according to EN 10111: DD12.

› Protection and Paint of Metal Parts

- Prior to powder coating, metal parts are treated with a three stage, non-acidic cleaning process to achieve superior finish adhesion. The finishing of the thermosetting polyester powder coating must be applied by electrostatic means with a minimum thickness of 70-80microns.
 - After coating, the parts must be oven cured to create a durable finishing that meets the following requirements:
 - Composition: Polyester powder suitable for outdoor use.
 - Cross Cut Test Adhesion according to UNE-EN ISO 2409 classification GT 0-1.
 - Scratch resistance according to ISO 15184:98 Level HB-H.
 - Total thickness: 70-80Microns.
 - Rust resistance (NSS), according to ISO 9220: 200 h.
 - Resistance to MEK 50 double rubs without paint stripping.

› Features of the plastic parts

- High pressure injection moulded seat and backrest buckets made of high impact copolymer polypropylene. High durability pigmented coloured plastic with textured exposed surface.
 - The armrests are made of blown polypropylene.

› Upholstery

• Integral Form / Traditional

- Group A: Figueras Fabrics ®

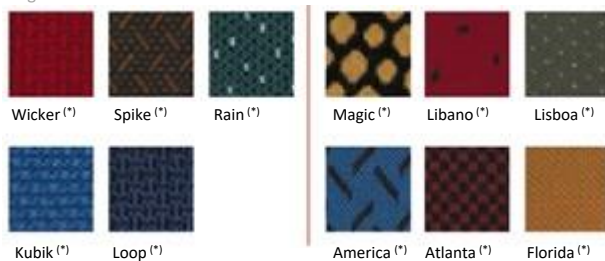

• Only Traditional

- Group A: Figueras Fabrics ®



- (*) Fabric sample / printed by collection. Check colours available.
- (*) Quotation for traditional upholstery upon request.

› Seat and Backrest Cushions Features

- The seat and backrest cushions are made of cold moulded polyurethane foam.
 - In the inside, both include metallic tube structures and steel plates, with springs. This system guarantees great comfort and avoids the appearance of deformations in the foams, even after an intensive use.
 - The headrest is also made of cold molded foam.
 - The upholstery of the cushions and headrest can be handcrafted, allowing all types of upholstery: woven, similar leather or natural leather. Within the range of products approved by Figueras.
 - This allows the seat to be customized according to each project's requirements.
 - Optionally, a fire barrier can be incorporated between the upholstery and the PUR foam.
 - They comply with all international fire behaviour requirements.
 - Seat foam density 60-65 kg/m³.
 - Backrest foam density 50-55Kg/m³.

- Group B:



- Group V:



- Group L:

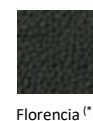

› Pigments for plastic parts



› Tecnowood finishes for plastic parts

